



INDUSTRIAL TOUCH SCREEN COMPUTER

VIO-219-PC100

19" SXGA 4:3 Resistive / Capacitive Touch Thin Frame Panel PC with Intel® Celeron® Processor J1900, 4x COM

Features

- 19" TFT SXGA 4:3 LCD with resistive 5-wire / projected capacitive touch
- Intel® Celeron® processor J1900, 2.0 GHz
- 1x 204-pin DDR3L SODIMM. max up to 8GB
- 1x 2.5" SATA HDD bay, 1x mSATA, 1x CFast, 2x SIM socket
- 2x full-size mini PCIe for communication or expansion modules
- 2x LAN, 1x VGA, 1x DisplayPort
- 6x RS-232/422/485 (w/ 2x internal), 1x USB 3.0, 3x USB 2.0, Audio
- 8x DI + 8x DO with isolation
- 9 to 50VDC wide range power input
- -10°C to 50°C extended operating temperature
- Designed with aluminum die-casting front frame
- IP65 compliant front panel
- Two 10W internal speakers built-in
- Multi-language OSD built-in



Specifications

Display	
IP Rating	IP65
LCD Size	19" (4:3)
Max. Resolution	1280 x 1024 (SXGA)
Brightness (cd/m ²)	350 / 1000 (optional)
Contrast Ratio	1000:1
LCD Color	16.7M
Pixel Pitch (mm)	0.294(H) x 0.294(V)
Viewing Angle	170/160
Backlight MTBF	50000 hrs (LED Backlight)
Touch	
Projected Capacitive	VIO-219C-PC100, VIO-219C-PC110
Resistive 5-Wire	VIO-219R-PC100, VIO-219R-PC110
System	
Processor	Intel® Celeron® Processor J1900, Quad Core, 2MB Cache, 2.0 GHz
System Chipset	SoC Integrated
LAN Chipset	GbE1 & GbE2: Intel® I210-AT (Support Wake-on-LAN and PXE)
System Memory	1x 204-Pin DDR3L 1333/1600MHz SODIMM up to 8GB
BIOS	AMI 64Mbit SPI BIOS
Watchdog	Software Programmable 1~255 sec. System Reset
Storage	
CFast	1x CFast (Shared by 1x mSATA & 1x Mini PCIe)
mSATA	1x mSATA (Shared by 1x Mini PCIe)
SIM Socket	2x External SIM socket
SSD/HDD	1 x Hotswap 2.5" SATA HDD Bay
Expansion	
Mini PCIe	1x Full-size Mini PCIe Socket with USIM Socket (PCIe + USB + SATA) 1x Full-size Mini PCIe Socket with USIM Socket (PCIe + USB)
I/O	
Audio	1x Mic-In, 1x line-out
COM	4x RS-232/422/485 2x RS-232/422/485 (internal)
DIO	8 in / 8 out (Isolated)
LAN	2x RJ45
Universal I/O Bracket	2x Universal I/O Bracket (By mini PCIe interface) (VIO-219-PC110 only)
USB	1x USB 3.0 3x USB 2.0
DP	1x DisplayPort
Others	3x Antenna 1x Power Switch 1x AT/ATX Switch 1x Remote Power On/Off

VGA	1x VGA
Others Features	
Speaker	AMP 10W + 10W
OSD	LCD On/Off, Auto, Menu, Up and Down Multi-language
Operating System	
Windows	Windows 10
Linux	Linux kernel 3.X
Power	
Power Adapter	Optional AC/DC 12V/5A, 60W
Power Management	Power Ignition Management
Power Mode	AT, ATX
Power Supply Voltage	9~50 VDC
Power Connector	3-Pin Terminal Block
Power Protection	OVP (Over Voltage Protection) OCP (Over Current Protection) Reverse Protection
Operating Temperature	-10 °C ~ 50 °C
Storage Temperature	-20 °C to 60 °C
Relative Humidity	10% ~ 80% (non-condensing)
IP Level	IP 65 Compliant Front Panel
Certification	CE, FCC Class A
Vibration	With SSD: 1.5 Grms, 5 - 500 Hz, 0.5 hr/axis With HDD: 1 Grms, 5 - 500 Hz, 0.5 hr/axis
Shock	20G, half sine, 11ms
Physical	
Dimensions	VIO-219/PC100: 450 (W) x 375 (D) x 71 (H) mm VIO-219/PC110: 450 (W) x 375 (D) x 93 (H) mm
Weights	7.18 ~ 7.26 kg
Mounting Options	VESA Mounting Holes 75 x 75mm, 100 x 100mm

External I/O Mechanical Layout

Front I/O

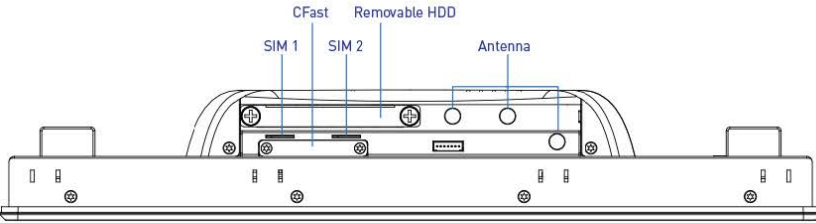

Left I/O

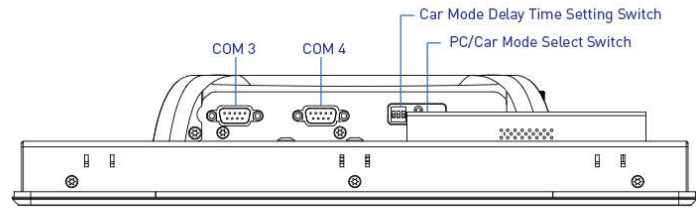

Rear I/O

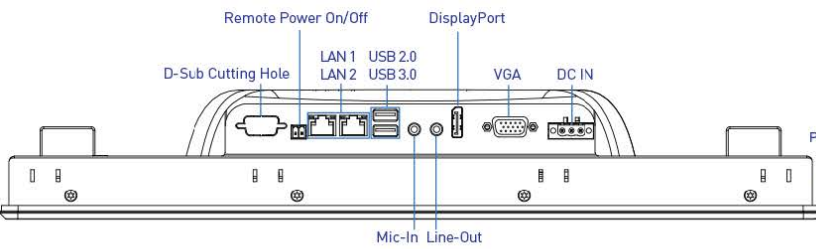

Right I/O

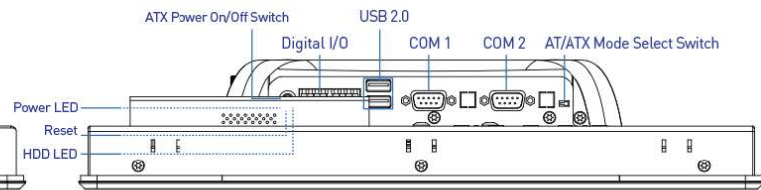

Dimension

Unit: mm

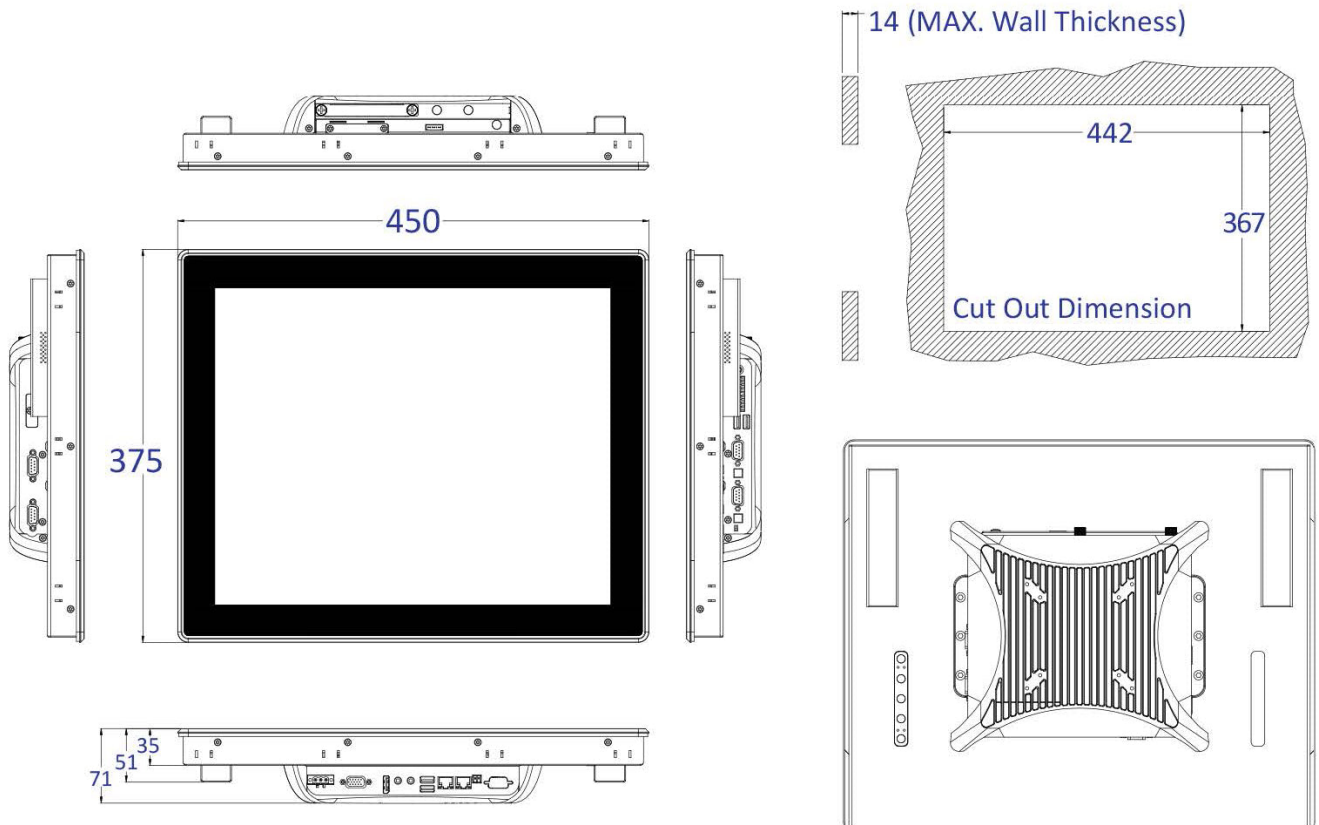

External I/O Mechanical Layout

Front I/O

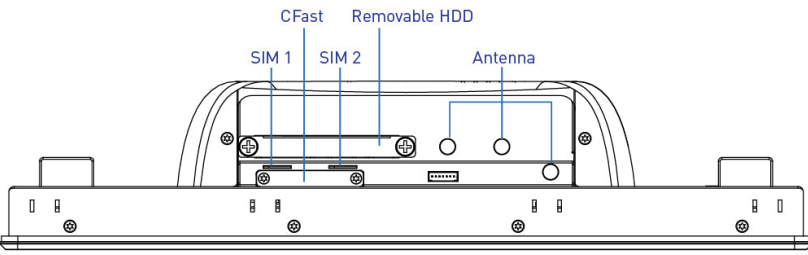

Left I/O

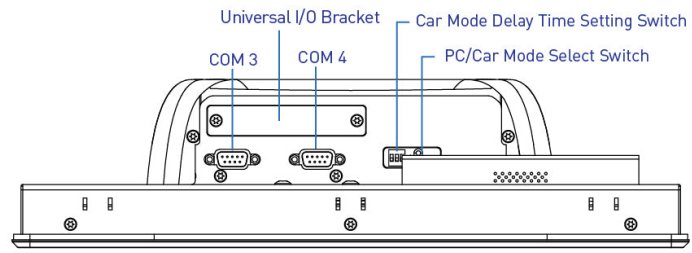

Rear I/O

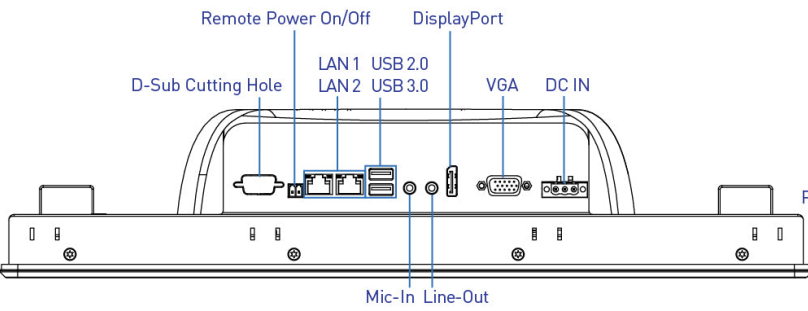

Right I/O

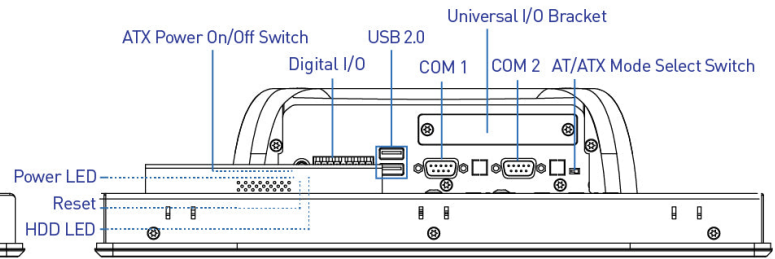

Dimension

Unit: mm

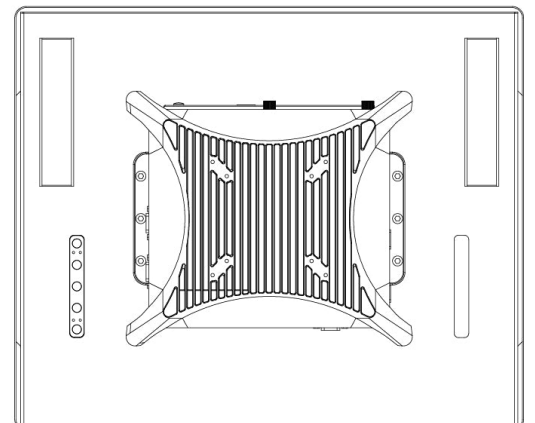
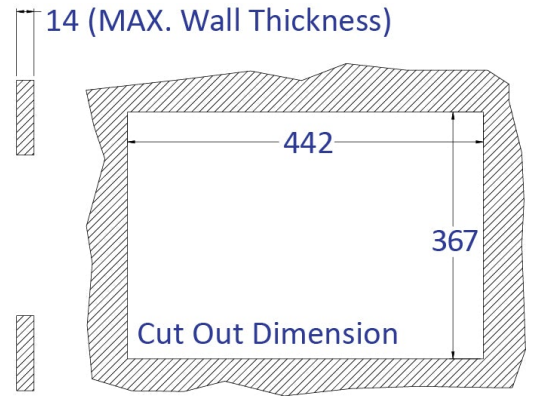
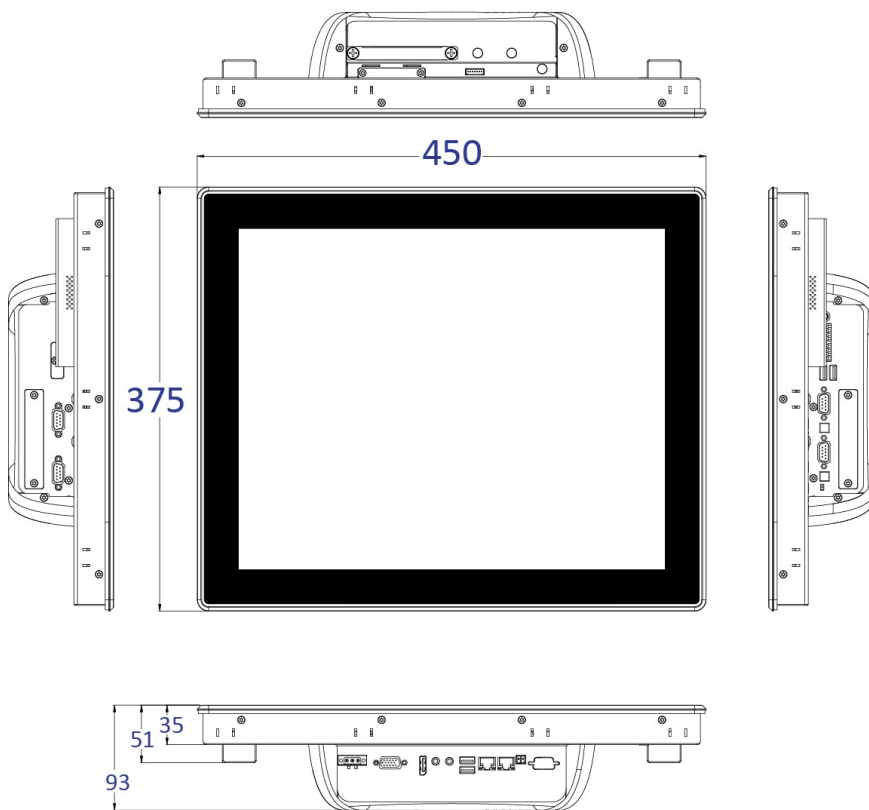

Available Models

Model No.	Description
VIO-219R-PC100-J1900	19" SXGA Resistive Touch Thin Frame Panel PC with Intel® Celeron® Processor J1900, 4x COM
VIO-219C-PC100-J1900	19" SXGA Capacitive Touch Thin Frame Panel PC with Intel® Celeron® Processor J1900, 4x COM
VIO-219R-PC110-J1900	19" SXGA Resistive Touch Thin Frame Panel PC with Intel® Celeron® Processor J1900, 4x COM, 2x Universal I/O Bracket
VIO-219C-PC110-J1900	19" SXGA Capacitive Touch Thin Frame Panel PC with Intel® Celeron® Processor J1900, 4x COM, 2x Universal I/O Bracket

Optional Accessories

Model No.	Description
1-E09A06008	Adapter AC/DC 12V 5A 60W with 3pin Terminal Block Plug 5.0mm Pitch
SFICBL022	Power Cord, 3-pin US Type, 180cm
1-TPCD00002	Power Cord, European Type
1-TPCD00001	Power Cord, 3-pin UK Type, 180cm

Packing List

- 1x VIO-219-PC100 Panel PC
- 14x Panel Mount Kit
- 1x Screw Pack