

USER'S MANUAL

RCO-3000-CML

Superior Fanless Embedded System



Table of Contents

Prefaces	04
Revision	04
Disclaimer	04
Copyright Notice	04
Trademarks Acknowledgment	04
Environmental Protection Announcement	04
Safety Precautions	05
Technical Support and Assistance	06
Conventions Used in this Manual	06
Package Contents	08
Ordering Information	08
Optional Accessory	08
Chapter 1 Product Introductions	09
1.1 Overview	10
Key Feature	10
1.2 Hardware Specification	11
1.3 System I/O	13
1.4 Mechanical Dimension	15
Chapter 2 Mechanical Specifications.....	16
2.1 Switch and connector Locations	17
2.1.1 Top View	17
2.1.2 Bottom View	18
2.2 Connector / Switch Definition	19
2.3 I/O Interface Descriptions	20
Chapter 3 System Setup	43
3.1 Set torque force to 3.5 kgf-cm to execute all the screwing and unscrewing	44
3.2 Removing chassis bottom cover	44
3.3 Removing chassis top cover	45
3.4 Installing SODIMM	46
3.5 Installing CPU	47
3.6 Installing mini PCIe card / mSATA / M.2	52
3.7 Installing antenna	53
3.8 Assembly chassis top cover	55
3.9 Installing HDD on internal SATA HDD bay	57
3.10 Installing HDD on removable SATA HDD tray	59
3.11 Assemble chassis bottom cover	60
3.12 Installing SIM card	61
3.13 Installing wall mount kit	62
3.14 Installing DIN rail holder	64
Chapter 4 BIOS Setup	66
4.1 BIOS Introduction	67
4.2 Main Setup	68
4.3 Advanced Setup	69
4.3.1 Connectivity Configuration	70

4.3.2 CPU Configuration	71
4.3.3 PCH-FW Configuration	72
4.3.4 SATA and RST Configuration	73
4.3.5 RST (UEFI RAID) Configuration	74
4.3.6 Trusted Computing	76
4.3.7 ACPI Settings	77
4.3.8 Super IO Configuration	78
4.3.9 Hardware Monitor	84
4.3.10 Serial Port Console Redirection	86
4.3.11 USB Configuration	87
4.3.12 Network Stack Configuration	88
4.4 Chipset	89
4.4.1 System Agent (SA) Configuration	89
4.4.2 PCH-IO Configuration	92
4.5 Security	97
4.6 Boot	100
4.7 Save & Exit	101
Appendix WDT & GPIO	102
WDT Sample Code	103
GPIO Sample Code	104

Prefaces

Revision

Revision	Description	Date
1.0	Manual Released	2023/6/19

Disclaimer

All specifications and information in this User's Manual are believed to be accurate and up to date. C&T Solution Inc. does not guarantee that the contents herein are complete, true, accurate or non-misleading. The information in this document is subject to change without notice and does not represent a commitment on the part of C&T Solution Inc.

C&T Solution Inc. disclaims all warranties, express or implied, including, without limitation, those of merchantability, fitness for a particular purpose with respect to contents of this User's Manual. Users must take full responsibility for the application of the product.

Copyright Notice

All rights reserved. No part of this manual may be reproduced or transmitted in any form or by any means, electronic or mechanical, including photocopying, recording, or information storage and retrieval systems, without the prior written permission of C&T Solution Inc. Copyright © C&T Solution Inc.

Trademarks Acknowledgment

Intel®, Celeron® and Pentium® are trademarks of Intel Corporation.

Windows® is registered trademark of Microsoft Corporation.

AMI is trademark of American Megatrend Inc.

IBM, XT, AT, PS/2 and Personal System/2 are trademarks of International Business Machines Corporation

All other products and trademarks mentioned in this manual are trademarks of their respective owners.

Environmental Protection Announcement

Do not dispose this electronic device into the trash while discarding. Please recycle to minimize pollution and ensure environment protection.

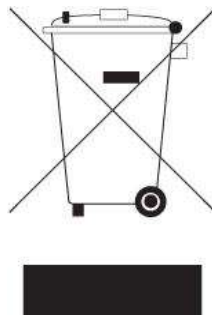

Safety Precautions

Before installing and using the equipment, please read the following precautions:

- Put this equipment on a reliable surface during installation. Dropping it or letting it fall could cause damage.
- The power outlet shall be installed near the equipment and shall be easily accessible.
- Turn off the system power and disconnect the power cord from its source before making any installation. Be sure both the system and the external devices are turned OFF. Sudden surge of power could ruin sensitive components. Make sure the equipment is properly grounded.
- When the power is connected, never open the equipment. The equipment should be opened only by qualified service personnel.
- Make sure the voltage of the power source is correct before connecting the equipment to the power outlet.
- Disconnect this equipment from the power before cleaning. Use a damp cloth. Do not use liquid or spray detergents for cleaning.
- Avoid the dusty, humidity and temperature extremes.
- Do not place heavy objects on the equipment.
- If the equipment is not used for long time, disconnect it from the power to avoid being damaged by transient over-voltage.
- The storage temperature shall be above -30°C and below 85°C .
- The computer is provided with a battery-powered real-time clock circuit. There is a danger of explosion if incorrectly replaced. Replace only with the same or equivalent type recommended by the manufacturer.
- If one of the following situation arises, get the equipment checked by service personnel:
 - The power cord or plug is damaged.
 - Liquid has penetrated into the equipment.
 - The equipment has been exposed to moisture.
 - The equipment does not work well or it cannot work according the user's manual.
 - The equipment has been dropped and damaged.
 - The equipment has obvious signs of breakage.

Technical Support and Assistance

1. Visit the C&T Solution Inc website at <https://www.candtsolution.com> where you can find the latest information about the product.
2. Contact your distributor, our technical support team or sales representative for technical support if you need additional assistance. Please have following information ready before you call:
 - Model name and serial number
 - Description of your peripheral attachments
 - Description of your software (operating system, version, application software, etc.)
 - A complete description of the problem
 - The exact wording of any error messages

Conventions Used in this Manual

**WARNING**

This indication alerts operators to an operation that, if not strictly observed, may result in severe injury.

**CAUTION**

This indication alerts operators to an operation that, if not strictly observed, may result in safety hazards to personnel or damage to equipment.

**NOTE**

This indication provides additional information to complete a task easily.

**NOTE**

Risk of explosion if battery is replaced by an incorrect type. Dispose of used batteries according to the instructions.

**NOTE**

This product is intended to be supplied by a Listed Power Adapter or DC power source, rated 9-48Vdc, 24.4-4.58A minimum, T_{ma} = 60 degree C minimum. If need further assistance, please contact C&T SOLUTION INC for further information."

**NOTE**

If using Class I adapter, power cord shall be connector to a socket-outlet with earthing connection.

**NOTE**

Input terminal block
Before connecting DC power inputs, makesure the DC power source voltage is stable.

- The wiring for the input terminal block shall be installed by a skilled person.
- Wire type: Cu
- Only use 30-12 AWG wire size and a torque value of 0.51 N-m.

**NOTE**

This equipment is to be connected to Power in PoE networks which would be not routing to outside plants.

Package Contents

Before installation, please ensure all the items listed in the following table are included in the package.

Item	Description	Q'ty
1	RCO-3000-CML Series Embedded System	1
2	Wall Mount Kit	1
3	Accessory Kit	1

Ordering Information

Model No.	Product Description
RCO-3000-CML	Advanced Fanless Embedded System w/ LGA 1200 for Intel® 10th Gen CPU & Q470E PCH, 2x LAN
RCO-3000-CML-4L	Advanced Fanless Embedded System w/ LGA 1200 for Intel® 10th Gen CPU & Q470E PCH, 6x LAN
RCO-3000-CML-4LM12	Advanced Fanless Embedded System w/ LGA 1200 for Intel® 10th Gen CPU & Q470E PCH, 2x LAN, 4x M12 LAN
RCO-3000-CML-D10G	Advanced Fanless Embedded System w/ LGA 1200 for Intel® 10th Gen CPU & Q470E PCH, 2x LAN, 2x 10G LAN
RCO-3000-CML-4U3	Advanced Fanless Embedded System w/ LGA 1200 for Intel® 10th Gen CPU & Q470E PCH, 2x LAN, 10x USB
RCO-3000-CML-M2MK	Small Form Factor Computerw/ LGA 1200 for Intel® 10th Gen CPU & Q470E PCH, 2x LAN, 1x M.2 M Key
RCO-3000-CML-2M2BK	Small Form Factor Computerw/ LGA 1200 for Intel® 10th Gen CPU & Q470E PCH, 2x LAN, 3x M.2 B Key

Optional Accessories

Model No.	Product Description
1-E09A12002	Adapter AC/DC 24V 5A 120W with 3pin Terminal Block Plug 5.0mm Pitch
1-E09A22102	Adapter AC/DC 24V 9.2A 220W with 3pin Terminal Block Plug 5.0mm Pitch
SFICBL022	Power Cord, 3-pin US Type, 180cm
1-TPCD00002	Power Cord, European Type, 180cm
1-TPCD00001	Power Cord, 3-pin UK Type, 180cm

Chapter 1

Product Introductions

1.1 Overview

The Advanced Fanless Embedded Systems RCO-3000-CML series are designed with rich I/O, high flexibility and easy expansion capabilities which are ideal for diverse industrial applications. Support 10th Gen. Intel® Core™ i9-10900TEE (4.5GHz, 10 Cores) / i7-10700TE (4.4GHz, 6 Cores) / i5-10500TE (3.7GHz, 6 Cores) / i3-10100TE (3.6GHz, 4 Cores) or Pentium® G6400TE (3.2GHz, Dual Core) / Celeron® G5900TE (3.0GHz, Dual Core) Desktop processor, RCO-3000-CML Series is an extreme features integration, outstanding system performance, versatile I/O connections, and rugged reliability fanless embedded systems. It offers dramatically enhanced CPU and graphics performance, wide power and feature advanced features, rich connectivity interfaces, wide range 9~48 VDC power input, and high reliability even operating in temperature extremes (-25°C to 70°C).



Key Features

- Support 10th Gen Intel® CML S Processor (LGA 1200, 35W TDP)
- Intel® Q470E Express Chipset
- Triple Independent Display by 3x DisplayPort
- 2x Intel® GbE supporting Wake-on-LAN and PXE
- 1x Full-size Mini PCIe and 2x External SIM socket
- 2x 2.5" SATA HDD Bay (1x Internal) and 1x mSATA, with RAID 0, 1, 5 support
- 1x M.2 (E Key, PCIe x1, USB 2.0, 2230)
- 1x M.2 (B Key, 2242/3042/3052, Support NVMe/5G/AI)
- 5x RS-232/422/485 (2x internal)
- 6x USB 3.2 Gen 2 (10 Gbps), 1x USB 3.2 Gen 1 (internal)
- 8x DI + 8x DO with isolation
- 9 to 48VDC Wide Range Power Input Supporting AT/ATX Mode
- Wide Operating Temperature (-25°C to 70°C)
- TPM 2.0 Supported
- UL Listed

1.2 Hardware Specification

System	
Processor Support 10th Gen Intel® CML S Processor (LGA 1200, 35W TDP) - Intel® Core™ i9-10900TE, 10 Cores, 20MB Cache, up to 4.5 GHz, TDP 35W - Intel® Core™ i7-10700TE, 8 Cores, 16MB cache, up to 4.4 GHz, TDP 35W - Intel® Core™ i5-10500TE, 6 Core, 12MB Cache, up to 3.7 GHz, TDP 35W - Intel® Core™ i3-10100TE, 4 Cores, 9MB Cache, up to 3.6 GHz, TDP 35W - Intel® Pentium® G6400TE, 2 Cores, 4MB Cache, 3.2 GHz, TDP 35W - Intel® Celeron® G5900TE, 2 Cores, 2MB Cache, 3.0 GHz, TDP 35W	
System Chipset	Intel® Q470E Express Chipset
LAN Chipset	<ul style="list-style-type: none"> GbE1: Intel I219 (Support Wake-on-LAN and PXE) 2.5 GbE2: Intel I225 (Support Wake-on-LAN and PXE)
Audio Codec	Realtek ALC888S
System Memory	2x 260-Pin DDR4 2666/2933MHz SODIMM. Max. up to 64GB
BIOS	AMI 256Mbit SPI BIOS
Watchdog	Software Programmable Supports 1~255 sec. System Reset
TPM	TPM 2.0
Display	
Display Port	3x DisplayPort, support resolution 4096 x 2304 (1x DP Port Co-layout HDMI Connector)
HDMI	Yes, Shared by 1x DP port
Multiple Display	Triple Display
Storage	
mSATA	1x mSATA
SIM Socket	2x External SIM socket (Mini PCIe attached)
SSD/HDD	<ul style="list-style-type: none"> 1x Internal 2.5" SATA HDD Bay (support H=9mm) 1x Removable 2.5" SATA HDD Bay (support H=7mm, hot-swappable) Support RAID 0, 1, 5
Operating System	
Windows	Windows 10
Linux	Linux kernel
Power	
Power Adaptor	Optional AC/DC 24V/5A, 120W Optional AC/DC 24V/9.2A, 220W
Power Mode	AT, ATX
Power Ignition Sensing	Power Ignition Management
Power Supply Voltage	9~48VDC
Power Connector	3-pin Terminal Block
Power Protection	OVP (Over Voltage Protection) OCP (Over Current Protection) Reserve Protection
Expansion	
M.2	1x M.2 (E Key, PCIe x1, USB 2.0, 2230), 1x M.2 B Key, 2242/3042/3052 (PCIe x2, Support AI Module/NVMe Storage) (PCIe x1 & USB 3.2 Gen1, Support 4G/5G)
Mini PCIe	1x Full-size Mini PCIe
Expansion Modules	Occupied One Universal I/O Slot: <ul style="list-style-type: none"> 4-port GbE module with Intel® I350 Chipset, RJ-45 or M12 connector (PoE optional) 2-Port 10GbE RJ45 with Intel X710 Chipset 4-Port USB with Renesas uPD720201K8 host controller (share PCIe Gen2 x1 bandwidth) 1x M.2 M Key (PCIe x4 Lane, 2242/2260) for NVMe/AI Module 2x M.2 B Key 2242/3042/3052: <ul style="list-style-type: none"> 1x M.2 (PCIe x2 Lane) for NVMe/AI Module 1x M.2 (PCIe x2 Lane) for NVMe/AI Module or 1x M.2 (PCIe x1 Lane + USB 3.2 Gen 1) for 4G/5G Module, 1x External SIM socket (M.2 attached)

Ethernet

- 4x 802.3at Compliant PoE Port, The Maximum DC Power Delivery on Each PoE is 25.5W
[RCO-3000-CML-4P Series and RCO-3000-CML-4PM12 Series only]

I/O

Audio	1x Line-out
CAN	2x CAN 2.0 A/B 2-pin Internal header
COM	3x RS-232/422/485 ; 2x RS-232/422/485 (internal)
DIO	8 in / 8 out (Isolated)
LAN	2x RJ45
Universal I/O Bracket	1x Universal I/O Bracket (By mini PCIe interface)
USB	6x USB 3.2 Gen 2 (10Gbps) 1x USB 3.2 Gen 1 (5 Gbps, internal) 1x USB 2.0 (internal)
Others	5x WiFi Antenna Holes 1x Power Switch, 1x AT/ATX Switch, 1x Remote Power On/Off 1x PC/Car Mode Switch, 1x Delay Time Switch 1x CMOS Battery 1x 4-Pin FAN Connector

Environment

Operating Temp.	-25°C to 70°C (35W CPU)
Storage Temp.	-30°C to 85°C
Relative Humidity	10% to 95% (non-condensing)
Vibration	With SSD: 5 Grms, 5 - 500 Hz, 0.5 hr/axis With HDD: 1 Grms, 5 - 500 Hz, 0.5 hr/axis
Shock	With SSD: 50G, half sine, 11ms
Standards / Certification	UL, CE, FCC Class A, EMC Conformity with EN50155 & EN50121-3-2

Physical

Construction	Extruded Aluminum with Heavy Duty Metal
Dimension	192 (W) x 227 (D) x 60.3 (H) mm
Weight	3.3kg - 4.1 kg
Mounting	Wall Mounting

1.3 System I/O

RCO-3000-CML

Rear Panel

DP/HDMI port

Used to connect a DP/HDMI monitor or connect optional split cable for dual display mode

Digital I/O Terminal Block

The Digital I/O terminal block supports 8 digital input and 8 digital output

DisplayPort

Used to connect a DisplayPort monitor

COM port

COM1 ~ COM3 support RS232/422/485 serial device

USB 3.2 Gen 2 Port

Used to connect USB 3.2 Gen 2

LAN port

Used to connect the system to a local area network

Antenna hole

Used to connect an antenna for optional Mini-PCIe WiFi module

DC IN

Used to plug a DC power input with terminal block

Car Mode Delay time select switch

Used to select car mode PC turn off delay time

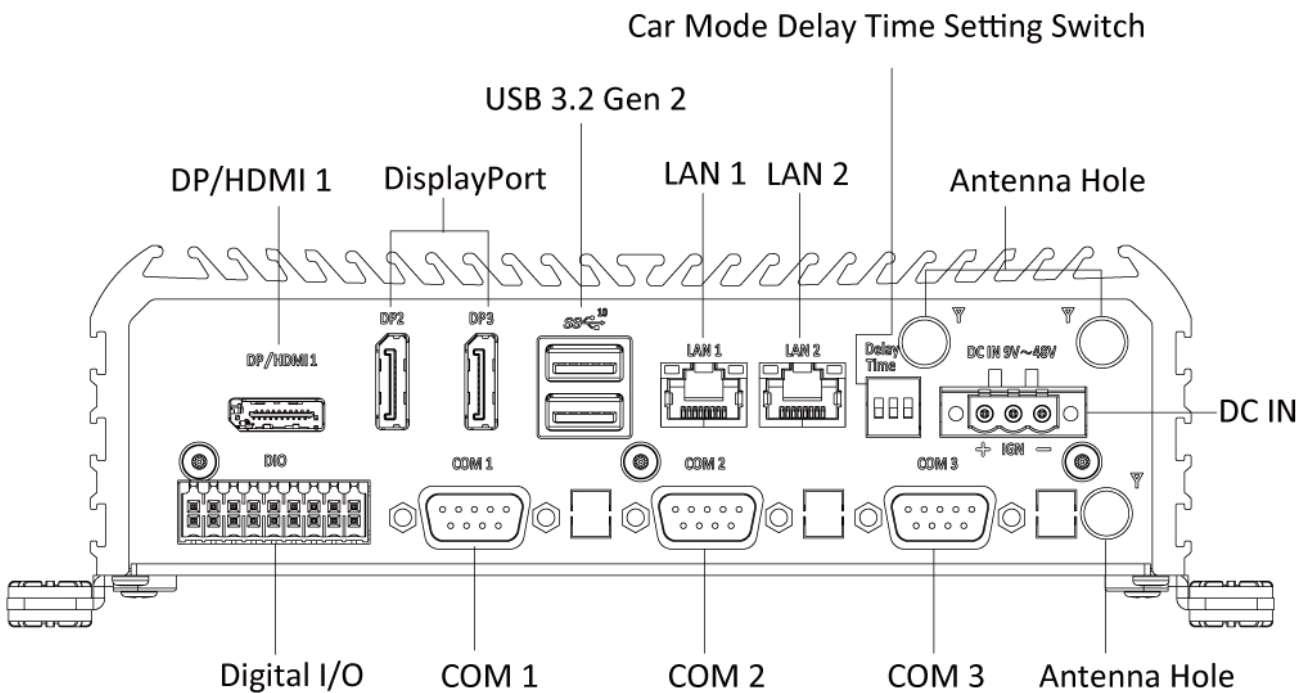

RCO-3000-CML

Front Panel

ATX power on/off switch

Press to power-on or power-off the system

Power LED

Indicates the power status of the system

HDD LED

Indicates the status of the hard drive

Antenna hole

Used to connect an antenna for optional Mini-PCIe WiFi module

USB 3.2 Gen 2 port (10 Gbps)

Used to connect USB 3.2 device

Removable HDD

Removable 2.5" SATA HDD Bay (support H=7mm, hot-swappable)
Support RAID 0, 1, 5

AT/ATX mode select switch

Used to select AT or ATX power mode

Remote Power on/off Terminal Block

Used to plug a remote power on/off terminal block

PC/Car mode select switch

Used to select PC or Car mode

【Universal I/O bracket】 optional

- **LAN Port**
Used to connect the system to a local area network
- **M12 LAN Port**
Used to connect the system to a local area network
- **D10G Port**
Used to connect the system to a local area
- **4x USB 3.2 Gen 2 Port**
Used to connect USB 3.2 Gen 2 device

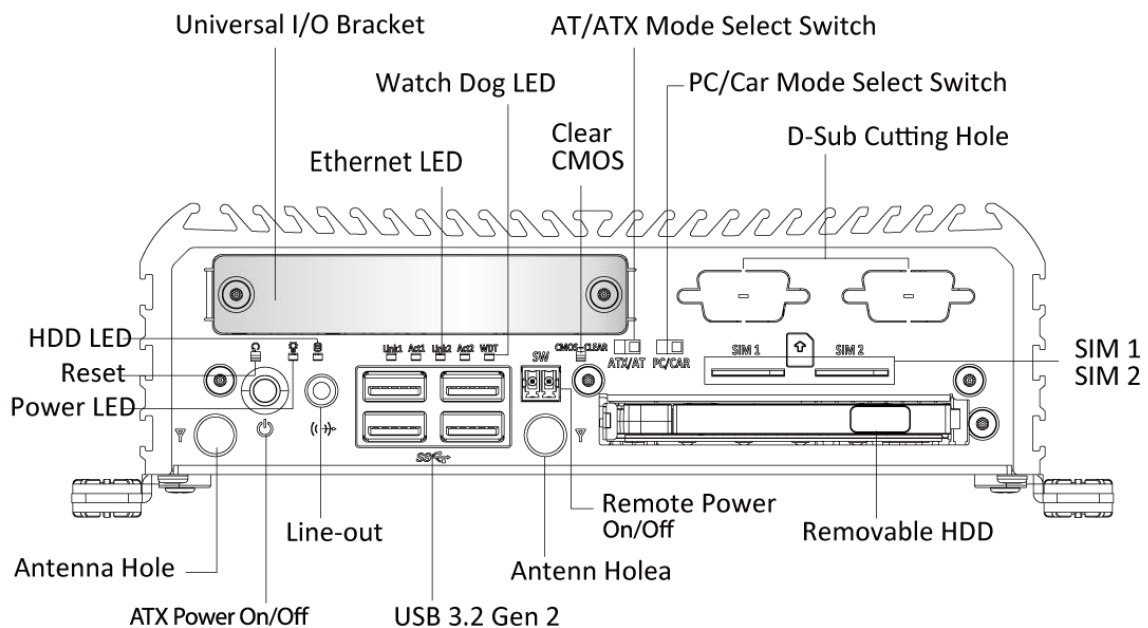

Available Modules

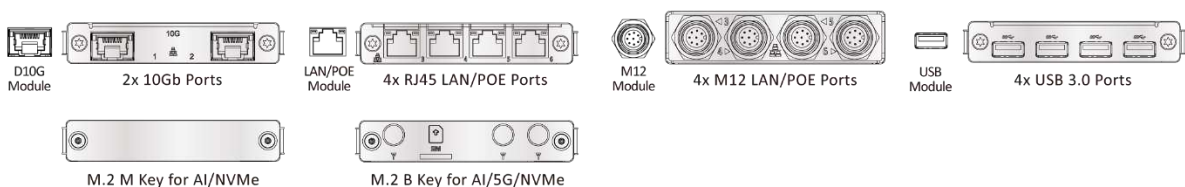

1.4 Mechanical Dimensions

RCO-3000-CML

Unit: mm

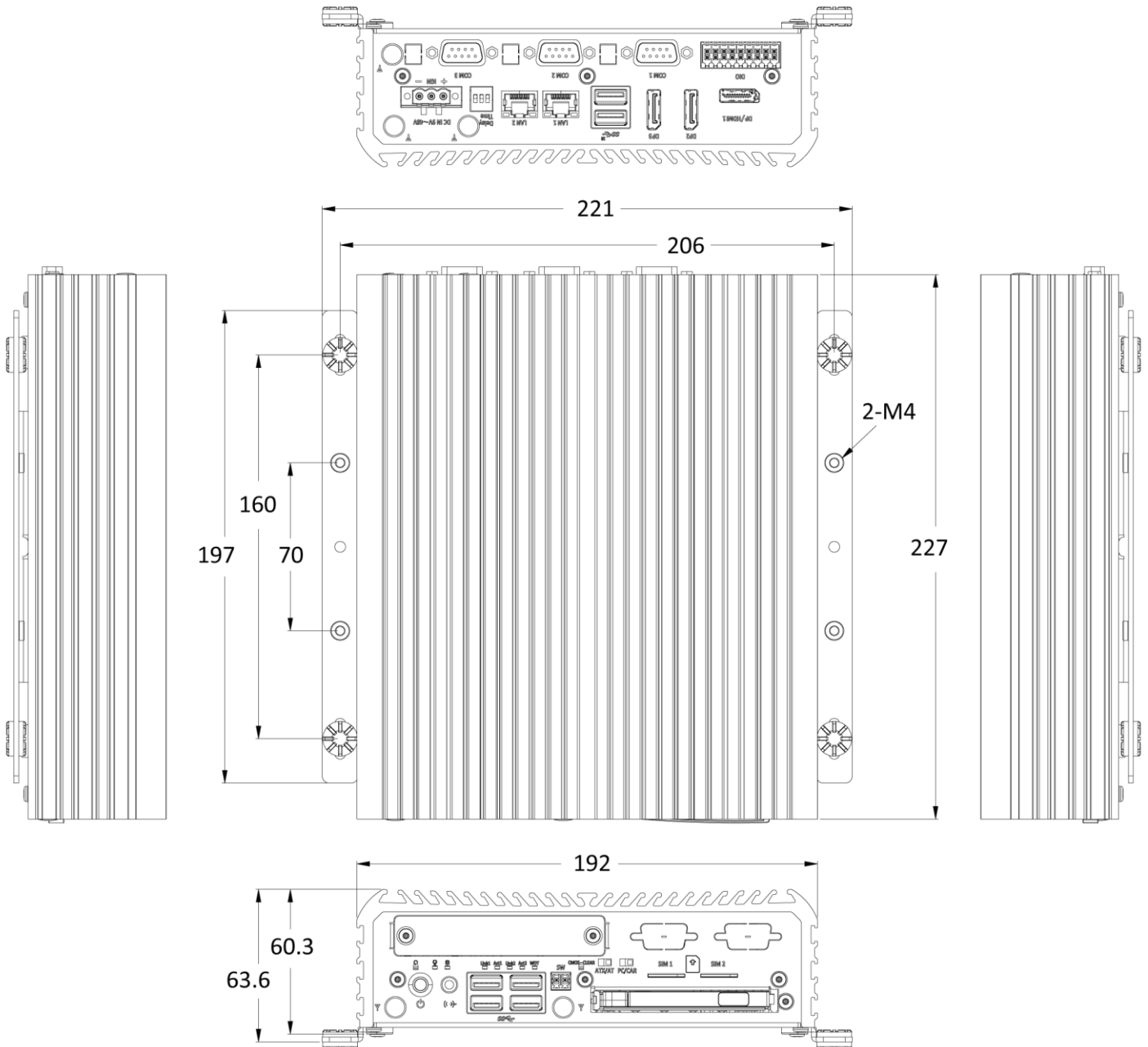

Chapter 2

Mechanical Specifications

2.1 Switch and Connector Locations

2.1.1 Top View

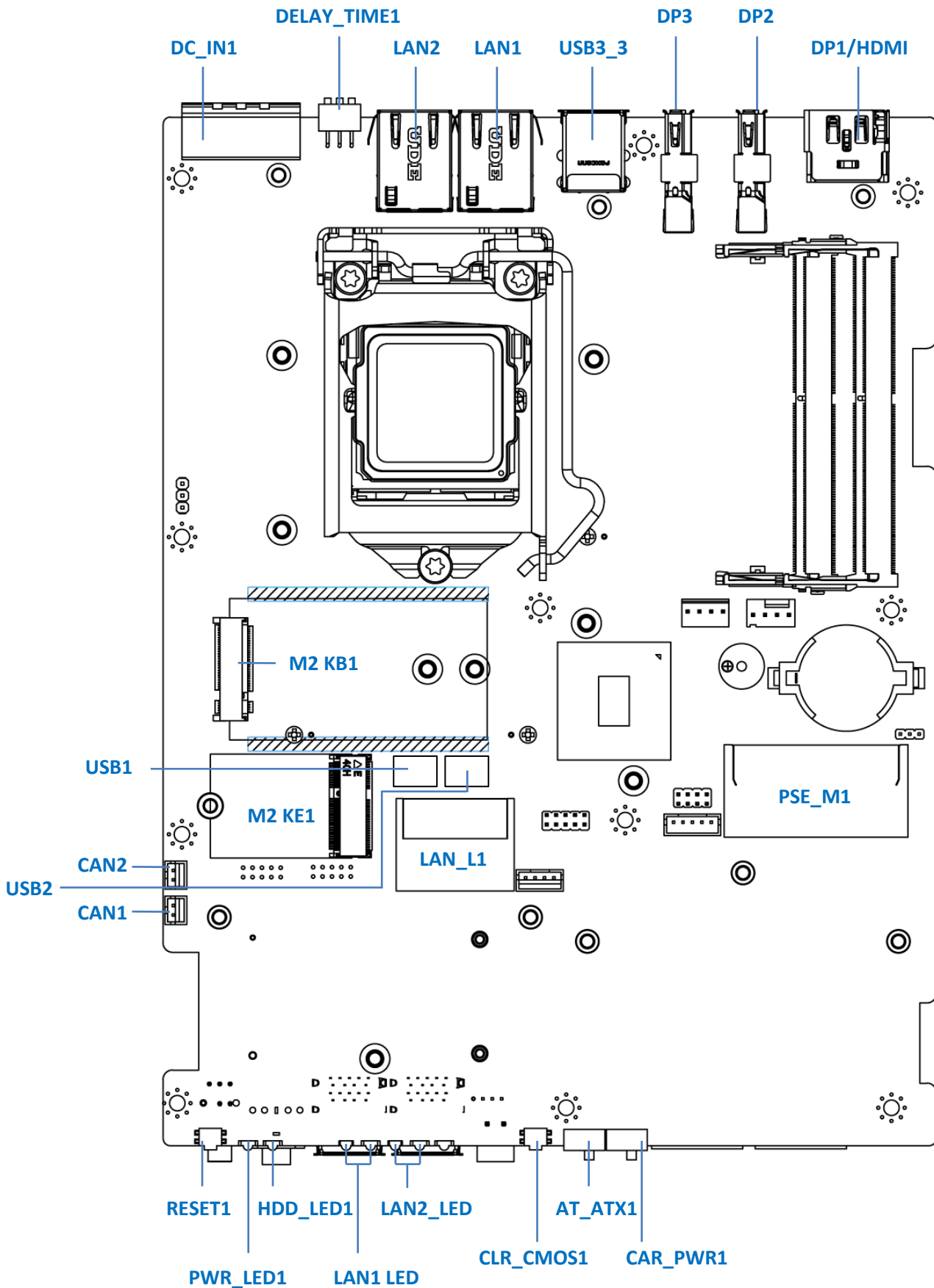

2.1.2 Bottom View

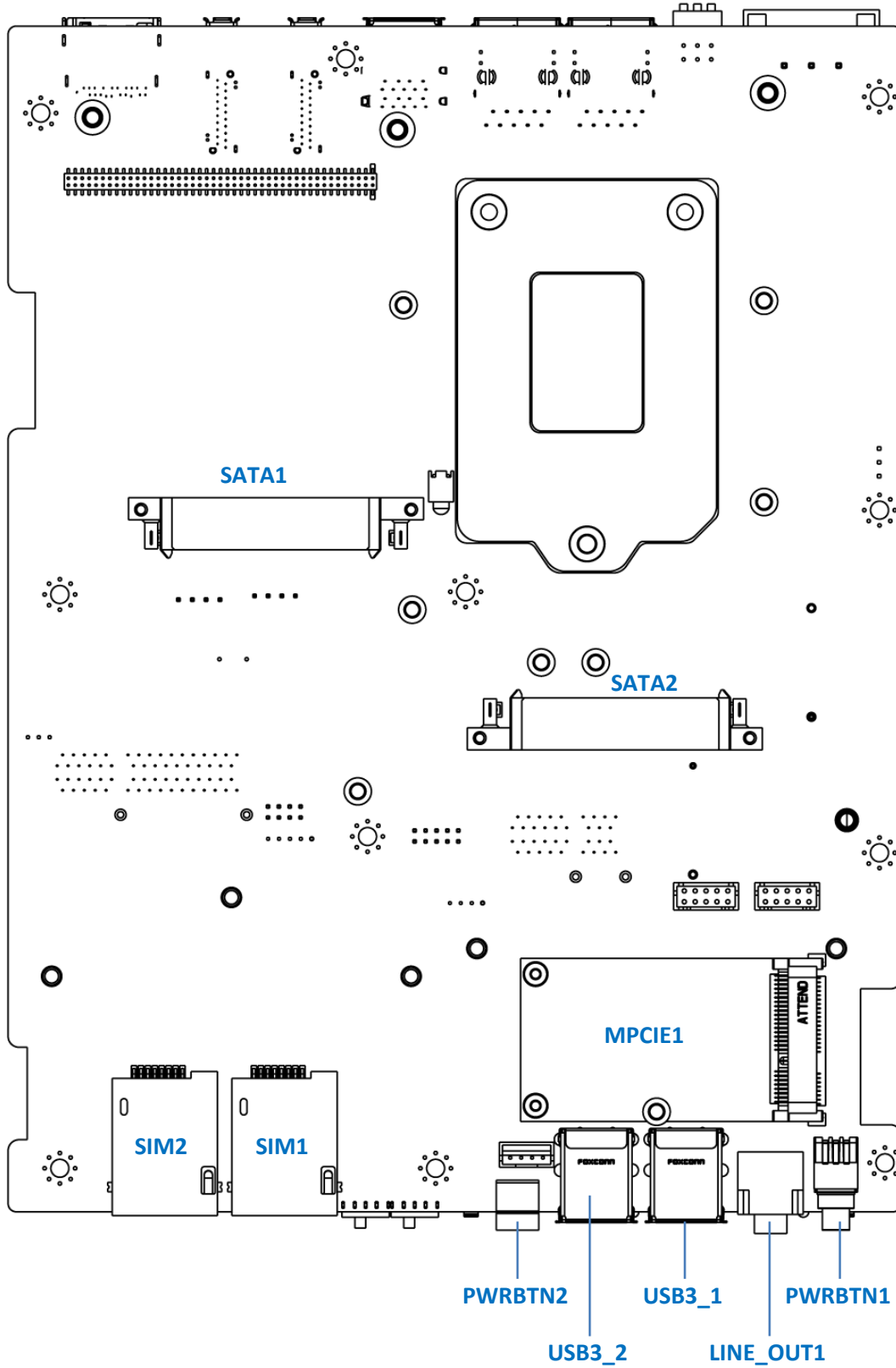

2.2 Connector / Switch Definition

Connector Location	Definition
DC_IN1	3-pin DC +9~48V Power Input Connector
DELAY_TIME	CAR mode delay time setting
LAN1 - 2	LAN Connector
USB3_1-3	USB 3.2 Gen 2 Connector
DP/HDMI	DP and HDMI Connector
DP2 - 3	DP Connector
RESET1	Reset Switch
PWR_LED	Power LED Status
HDD_LED	HDD Access LED Status
LAN1-2_LED	LAN Link-Active LED
CLR_CMOS1	Clear CMOS Switch
AT_ATX1	AT / ATX Power Mode Switch
CAR_PWR1	PC mode / CAR mode select
SATA1-2	SATA with Power Connector
MPCIE1	Mini PCI Express slot with SIM and mSATA
PWRBTN1-2	Power Switch
LINE_OUT1	LINE-OUT Jack
SIM1-2	SIM Card Socket
M2_KB1	M.2 B-Key Socket
M2_KE1	M.2 E-Key Socket
COM1, COM2, COM3	COM Serial Port
DIO1	8IN/8OUT GPIO Connector
CAN1-2	CAN BUS Connector

2.3 I/O Interface Descriptions

2.3.1 DC IN/IGN IN (+9V ~ +48V)

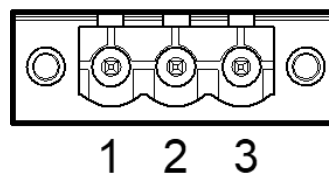
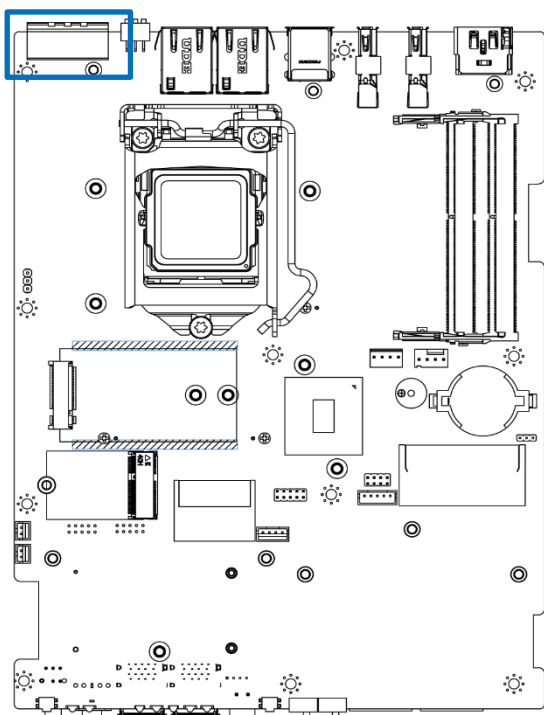

DC_IN1

Pin	Signal
1	+DC_IN
2	IGN_SENSE
3	GND

2.3.2 Power off delay time setup Switch

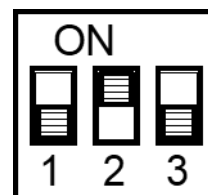
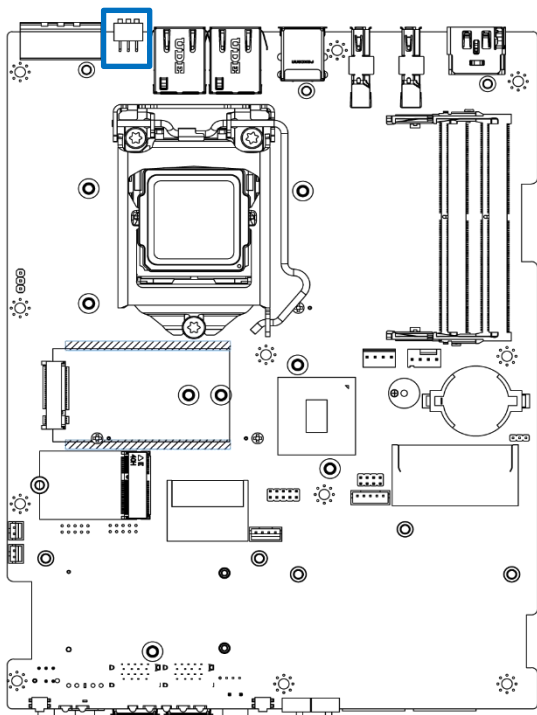

DELAY_TIME1

Pin	Signal
ON / ON / ON	3 sec. (Default Shutdown Timer by O.S)
ON / ON / OFF	1 min.
ON / OFF / ON	5 min.
ON / OFF / OFF	10 min.
OFF / ON / ON	30 min.
OFF / ON / OFF	1 hour
OFF / OFF / ON	2 hour

2.3.3 LAN1-2

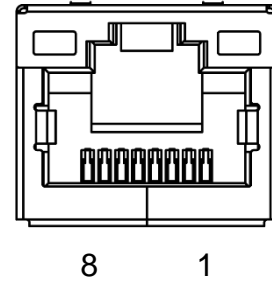
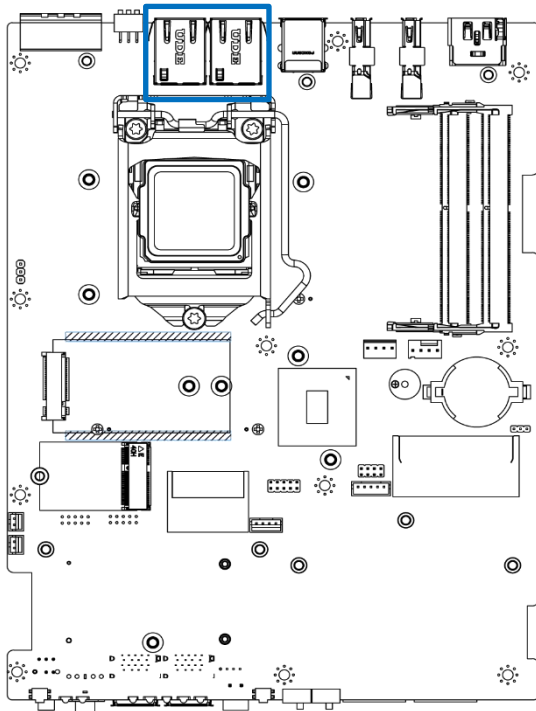

LAN1-2

Pin	Signal
1	LAN1_MDI0P
2	LAN1_MDI0N
3	LAN1_MDI1P
4	LAN1_MDI2P
5	LAN1_MDI2N
6	LAN1_MDI1N
7	LAN1_MDI3P
8	LAN1_MDI3N

2.3.4 USB3_1-3 Connector

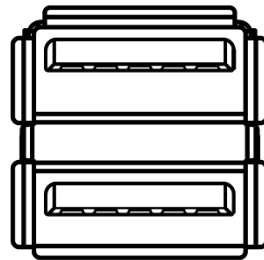
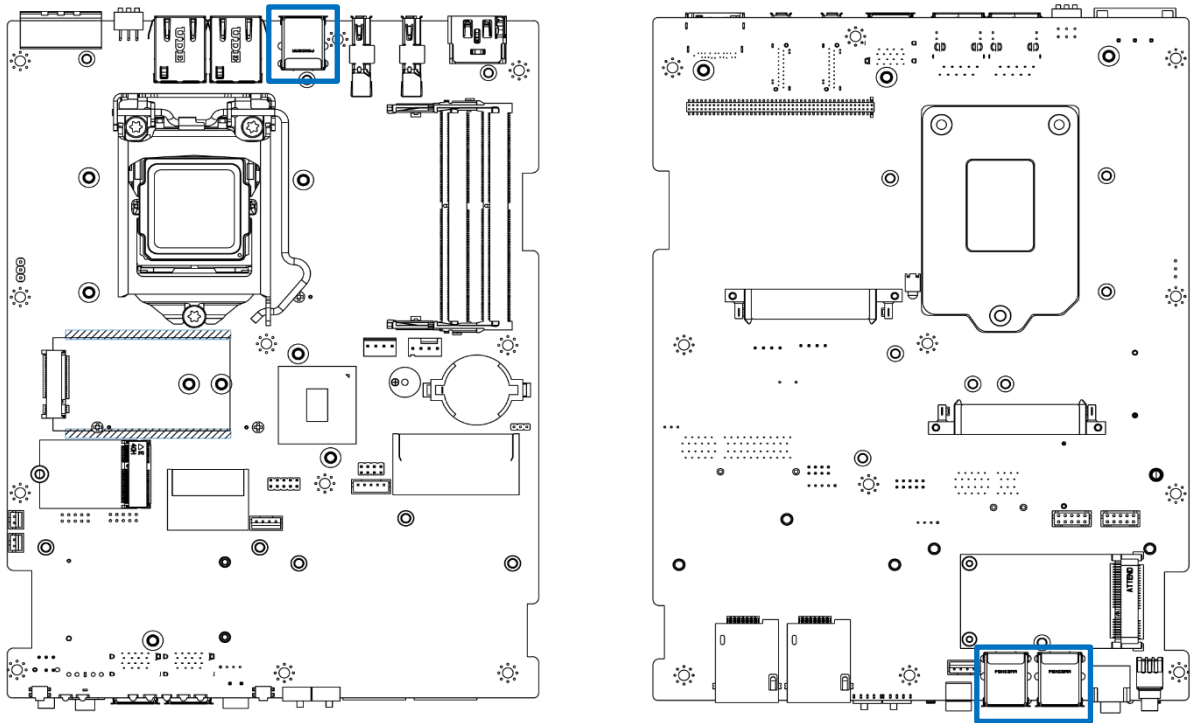

GEN2 x6 ports, Type A

Pin	Signal	Pin	Signal
1	+5V	6	USB3_RX+
2	USB2_D-	7	GND
3	USB2_D+	8	USB3_TX-
4	GND	9	USB3_TX+
5	USB3_RX-		

2.3.5 Display Port Connector

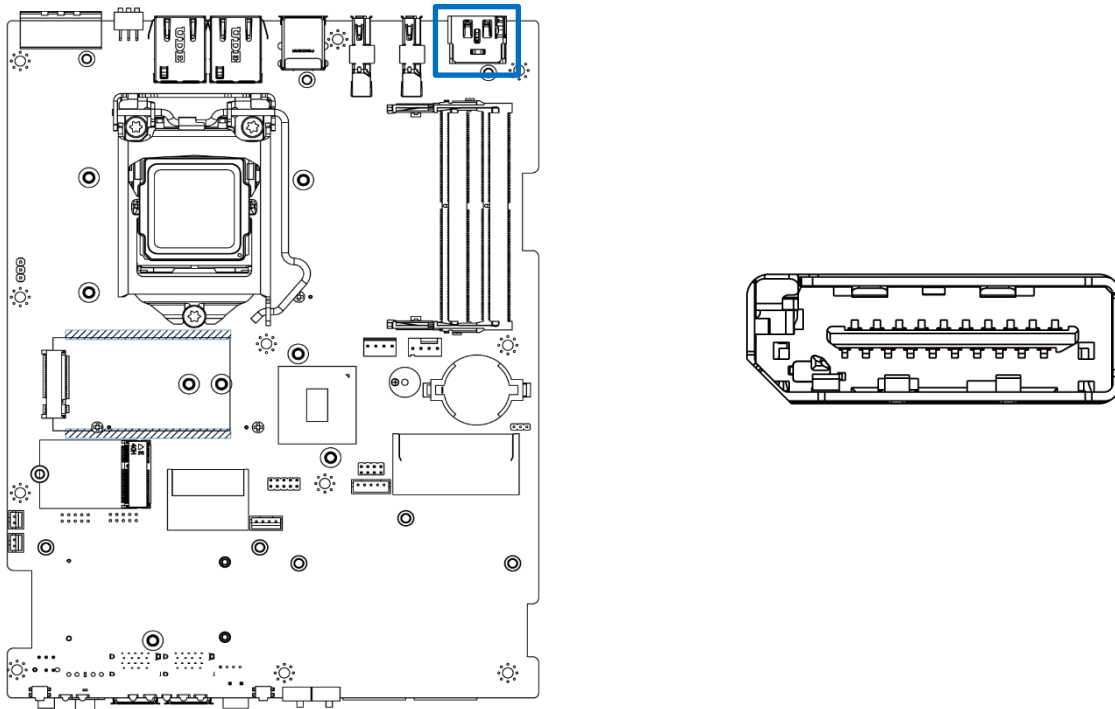

DP1/HDMI

Pin	Signal	Pin	Signal
1	DP_LANE0_P	11	GND
2	GND	12	DP_LANE3_N
3	DP_LANE0_N	13	GND
4	DP_LANE1_P	14	GND
5	GND	15	DP_AUX_P/ HDMI_DDCCLK
6	DP_LANE1_N	16	HDMI_DAT
7	DP_LANE2_P	17	DP_AUX_N/HDMI_DDCDAT
8	GND	18	DP_HPD
9	DP_LANE2_N	19	HDMI_HPD
10	DP_LANE3_P	20	+3.3V
		21	DP_DET_N

Display Port Connector

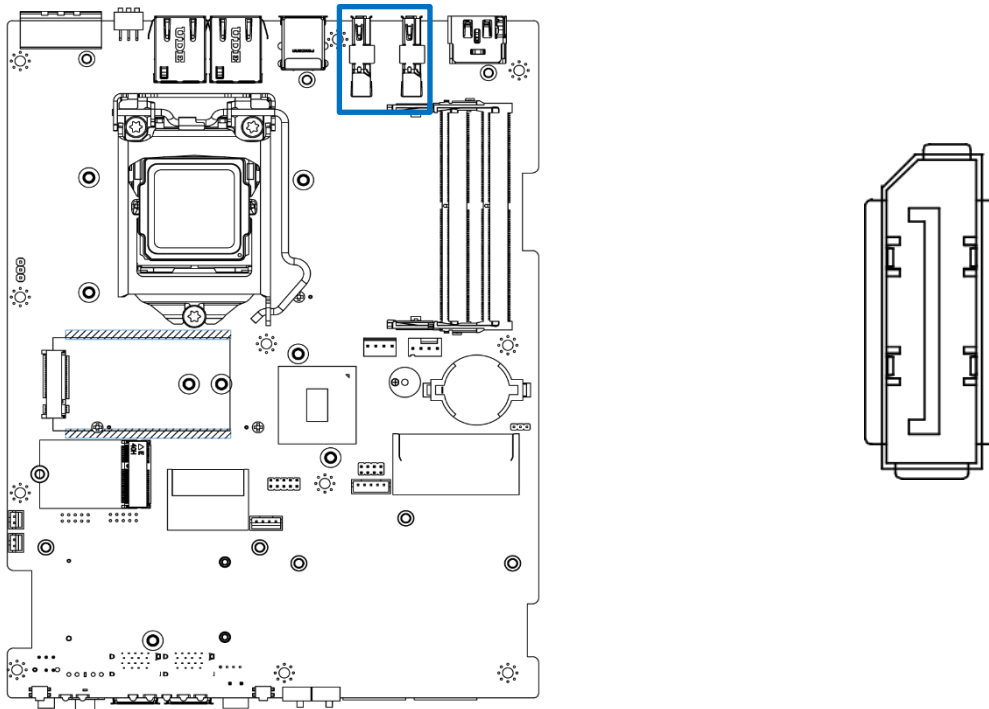

DP1 DP2

Pin	Signal	Pin	Signal
1	DP_LANE0_P	11	GND
2	GND	12	DP_LANE3_N
3	DP_LANE0_N	13	GND
4	DP_LANE1_P	14	GND
5	GND	15	DP_AUX_P
6	DP_LANE1_N	16	GND
7	DP_LANE2_P	17	DP_AUX_N
8	GND	18	DP_HPD
9	DP_LANE2_N	19	GND
10	DP_LANE3_P	20	+3.3V

2.3.6 Reset Button

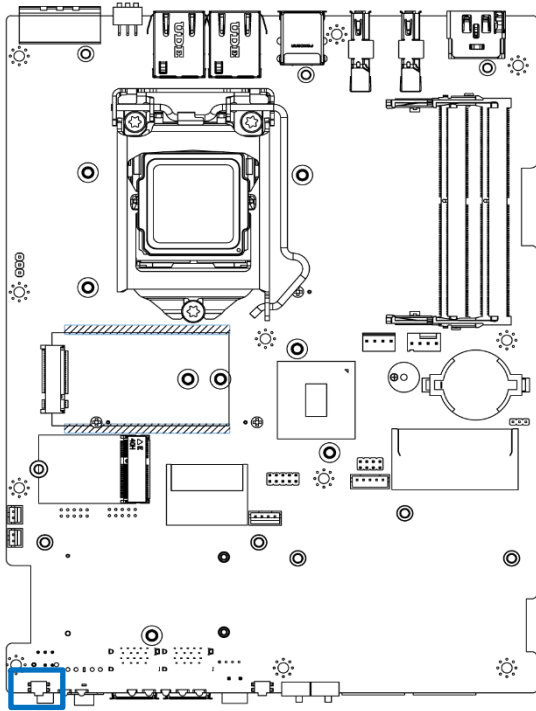

RESET1

Pin	Signal
1,2	RESET
3,4	GND

2.3.7 LED Status

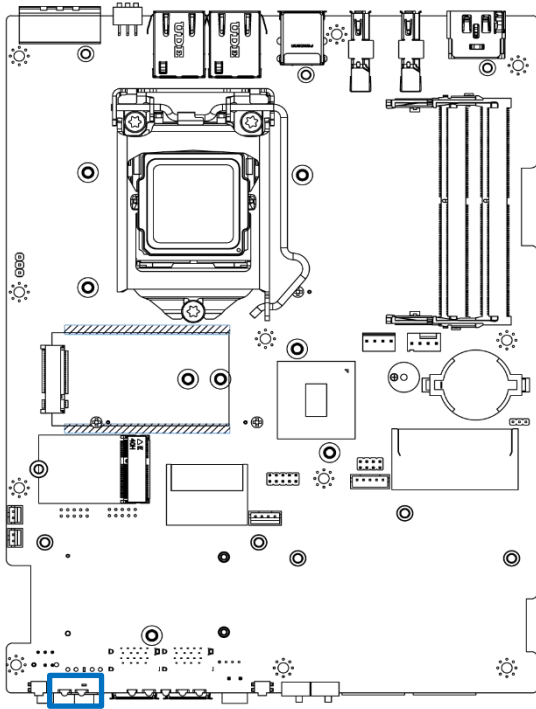

PWR_LED: Power LED Status

Pin	Definition
1	POWER LED +
2	POWER LED -

HDD_LED: HDD Access LED Status

Pin	Definition
1	HDD LED+
2	HDD LED-

2.3.8 LAN1, LAN2 LED Status

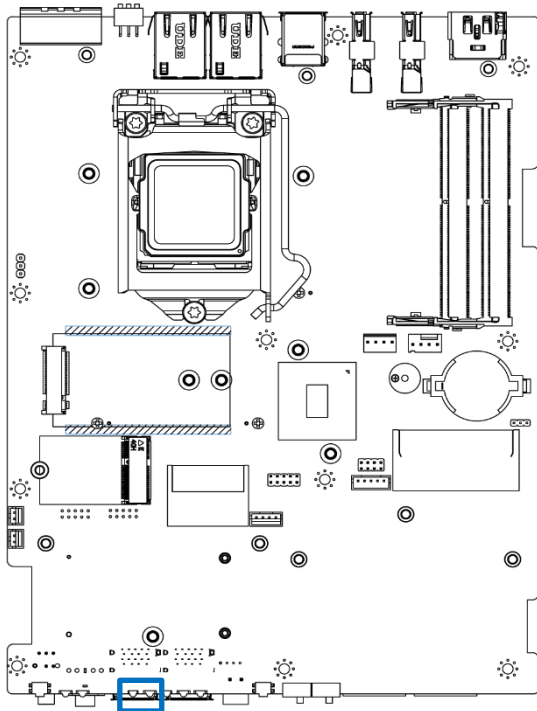

 **LAN1 LED**

Act LED Status	Definition
Blinking Yellow	Data Activity
Off	No Activity



Link LED Status	Definition
Steady Orange	1Gbps Network Link
Steady Green	100Mbps Network Link
Off	10Mbps Network Link

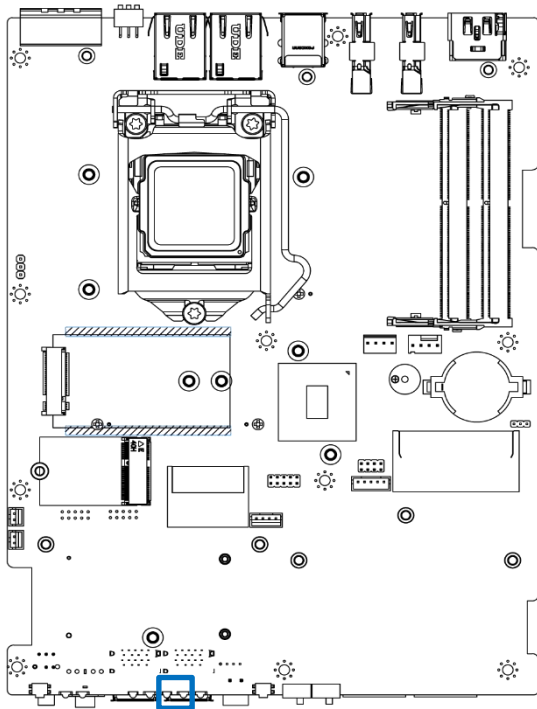

 **LAN2 LED**

Act LED Status	Definition
Blinking Yellow	Data Activity
Off	No Activity



Link LED Status	Definition
Steady Orange	1Gbps Network Link
Steady Green	2.5Gbps Network Link
Off	100Mbps Network Link

2.3.9 Clear BIOS Switch

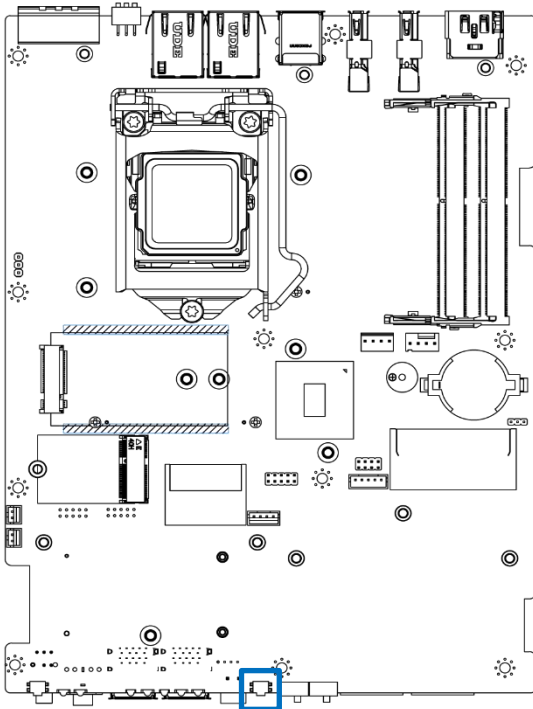

CLR_CMOS1

Pin	Signal
Push	Clear BIOS
open	Normal Status (Default)

2.3.2 AT / ATX Power Mode Switch

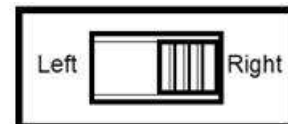
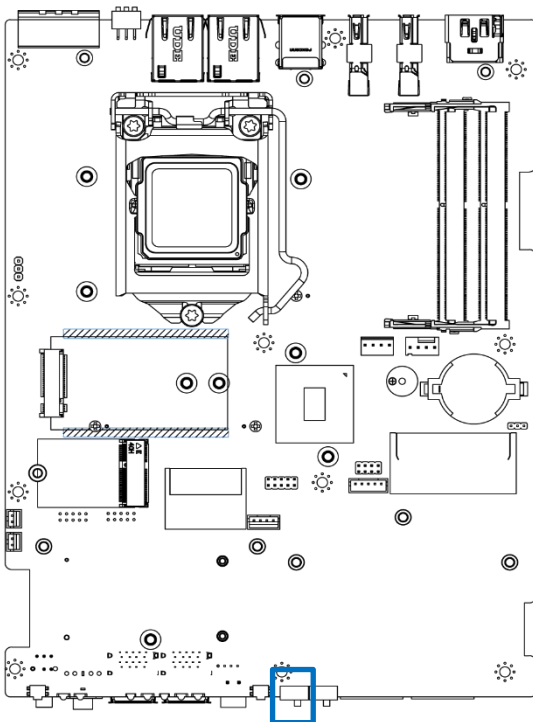

AT_ATX1

Switch	Signal
1-2 (Left)	ATX Power Mode (Default)
2-3 (Right)	AT Power Mode

2.3.10 PC/Car Mode Switch

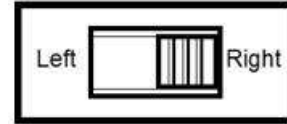
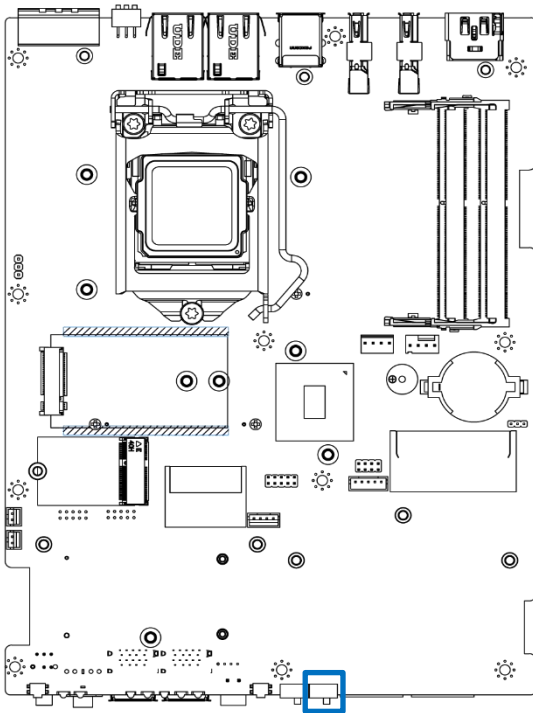

CAR_PWR1

Switch	Signal
1-2 (Left)	PC Power Mode (Default)
2-3 (Right)	Power Ignition Mode

2.3.11 SATA with Power Connector

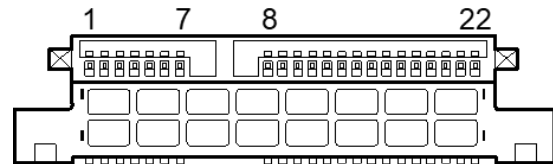
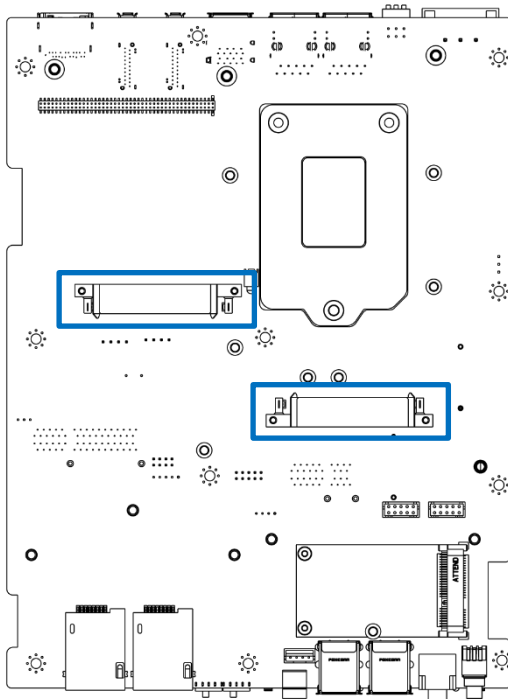

SATA1-2

Pin	Definition
1	GND
2	TxP
3	TxN
4	GND
5	RxN
6	RxP
7	GND
8	NC
9	NC
10	DEVSLP
11	GND

Pin	Definition
12	GND
13	GND
14	+5V
15	+5V
16	+5V
17	GND
18	GND
19	GND
20	NC
21	NC
22	NC

2.3.12 Mini PCI-Express Socket

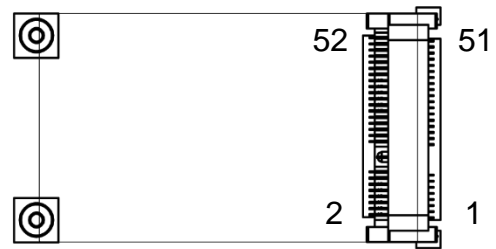
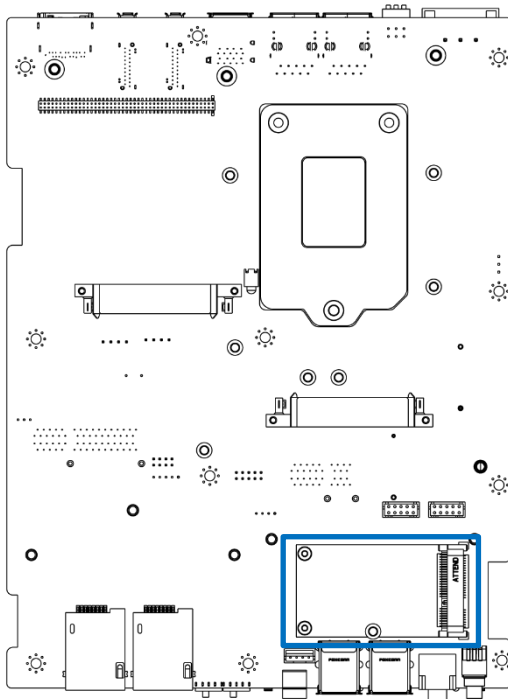

MPCIE1

Pin	Definition	Pin	Definition
1	WAKE#	2	+3.3V
3	NC	4	GND
5	NC	6	+1.5V
7	CLKREQ#	8	UIM_PWR
9	GND	10	UIM_DATA
11	REFCLK-	12	UIM_CLK
13	REFCLK+	14	UIM_RST
15	GND	16	UIM_VPP
17	NC	18	GND
19	NC	20	NC
21	GND	22	RESET#
23	RxN	24	+3.3VAUX
25	RxP	26	GND
27	GND	28	+1.5V

Pin	Definition	Pin	Definition
29	GND	30	SMB_CLK
31	TxN	32	SMB_DATA
33	TxP	34	GND
35	GND	36	USB2_D-
37	GND	38	USB2_D+
39	+3.3V	40	GND
41	+3.3V	42	NC
43	GND	44	NC
45	NC	46	NC
47	NC	48	+1.5V
49	NC	50	GND
51	NC	52	+3.3V

2.3.13 Power Button

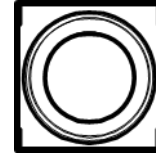
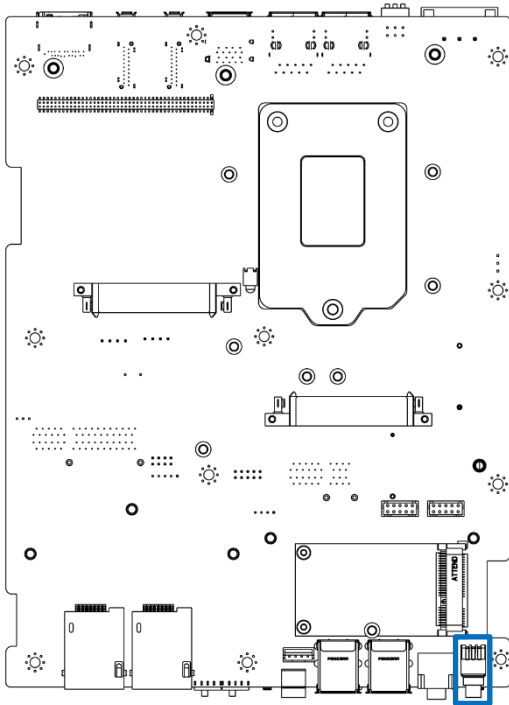

PWRBTN1

Pin	Definition
1	NC
2	Power Button
3	NC
4	GND
5	NC
6	GND

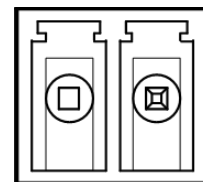
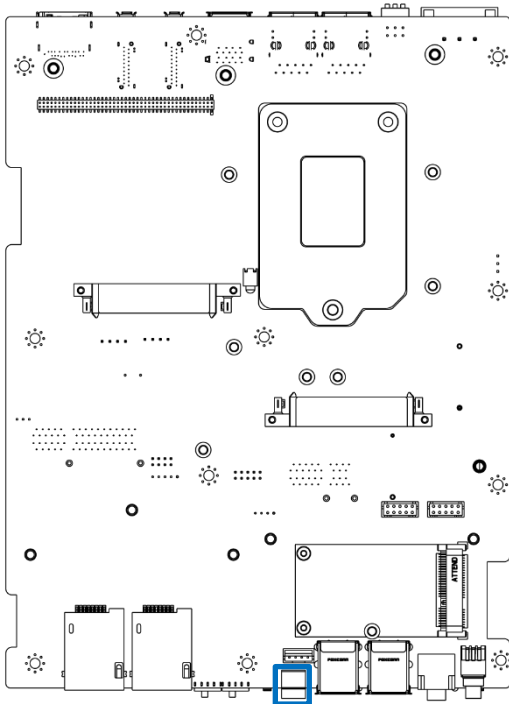

PWRBTN2

Pin	Definition
1	Power Button
2	GND

2.3.14 Line-out Jack (Green) Connector Type: 5-pin Phone Jack

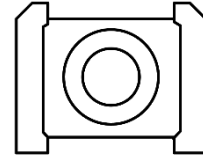
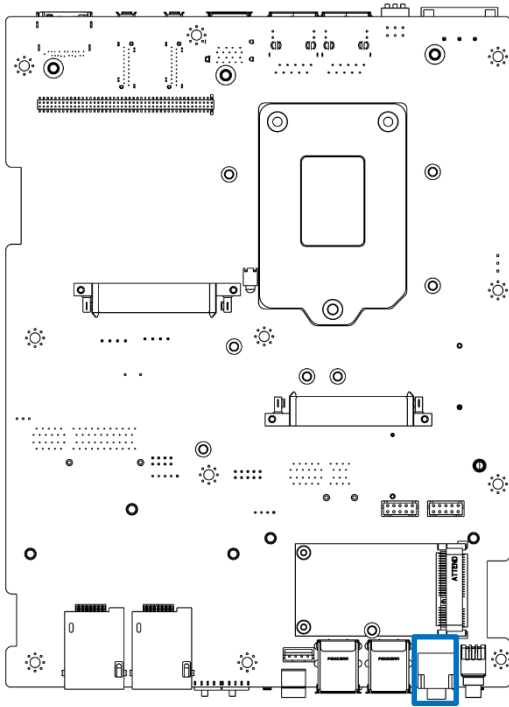

LINE_OUT1

Pin	Definition
1	GND
2	OUT_R
3	GND
4	GND
5	OUT_L

2.3.15 Bottom size SIM Card Socket

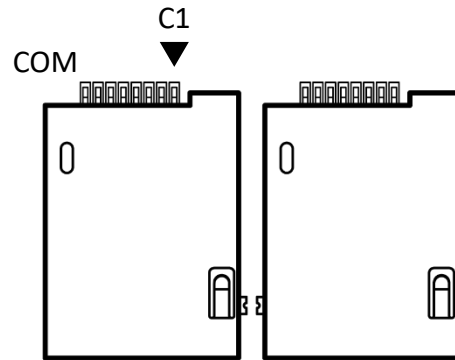
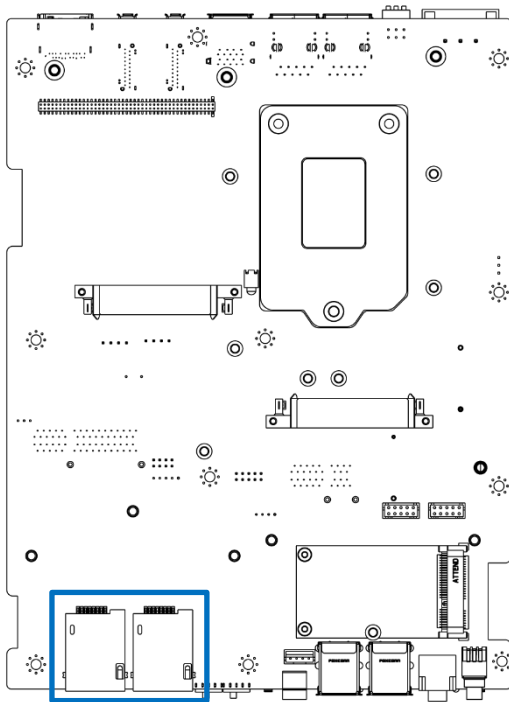

SIM1-2

Pin	Definition	Pin	Definition
C1	UIM_PWR	C6	UIM_VPP
C2	UIM_RESET	C7	UIM_DATA
C3	UIM_CLK	CD	NC
C5	GND	COM	GND

2.3.16 M.2 B-Key Socket

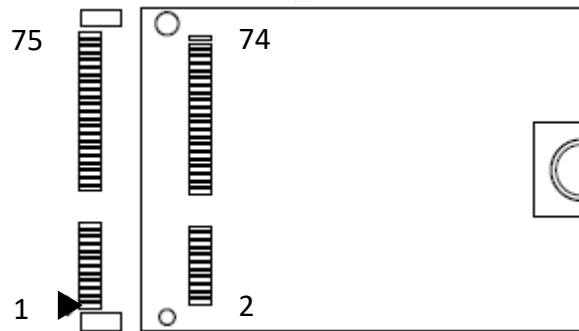
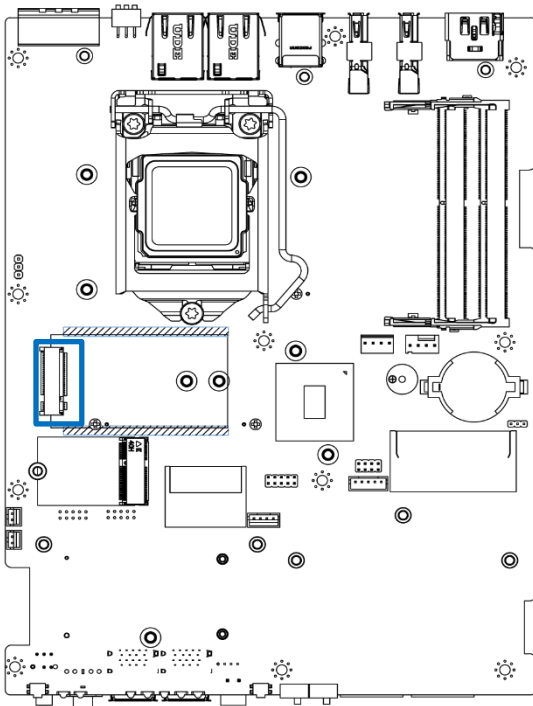

M2_KB1

Pin	Definition	Pin	Definition
1	+3.3V	2	+3.3V
3	GND	4	+3.3V
5	GND	6	+1.8S
7	USB2_D+	8	+3.3V
9	USB2_D-	10	NC
11	GND		
21	+3.3V	20	NC
23	NC	22	NC
25	NC	24	NC
27	GND	26	NC
29	PCIE2/USB_RxN0	28	NC
31	PCIE2/USB_RxP0	30	SIM_RST
33	GND	32	SIM_CLK
35	PCIE2/USB_TxN0	34	SIM_DATA

Pin	Definition	Pin	Definition
37	PCIE2/USB_TxP0	36	SIM_PWR
39	GND	38	NC
41	PCIE1_RxN0	40	NC
43	PCIE1_RxP0	42	NC
45	GND	44	NC
47	PCIE1_TxN0	46	NC
49	PCIE1_TxP0	48	NC
51	GND	50	PCIE_RST#
53	REFCLK1-	52	CLK_REQ#
55	REFCLK1+	54	PCIE_WAKE#
57	GND	56	NC
59	NC	58	NC
61	NC	60	NC
63	NC	62	NC
65	NC	64	NC
67	NC	66	NC
69	+3.3V	68	NC
71	GND	70	+3.3V
73	GND	72	+3.3V
75	+3.3V	74	+3.3V

2.3.17 M.2 E-Key Socket

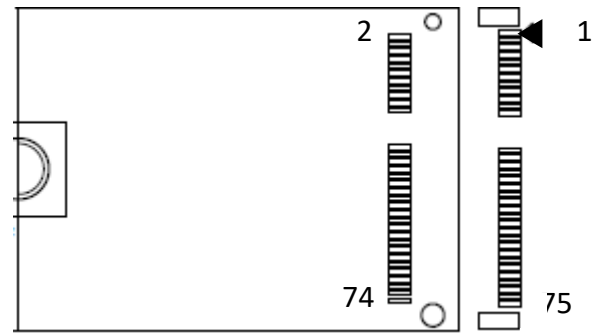
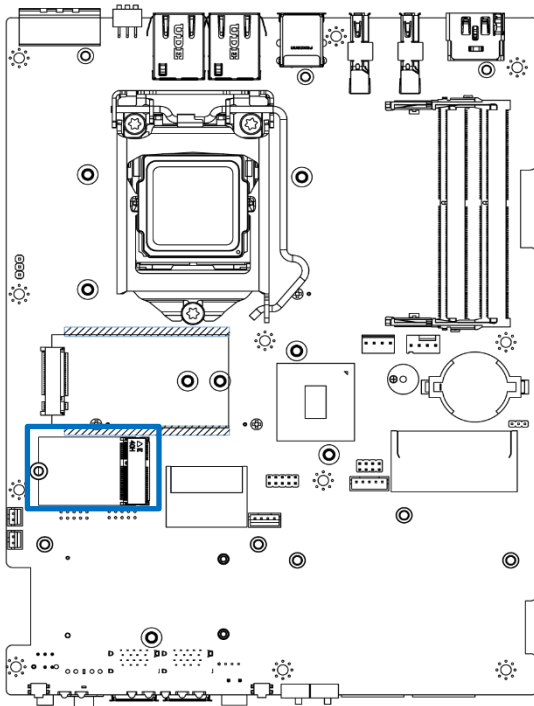

M2_KE1

Pin	Definition	Pin	Definition
1	GND	2	+3.3V
3	USB2_D+	4	+3.3V
5	USB2_D-	6	NC
7	GND	8	PCM_CLK
9	CNV_WR_1_DN	10	PCM_SYNC
11	CNV_WR_1_DP	12	PCM_IN
13	GND	14	PCM_OUT
15	CNV_WR_0_DN	16	NC
17	CNV_WR_0_DP	18	GND
19	GND	20	UART_BT_WAKE#
21	CNV_WR_CLK_DN	22	CNV_BRI_RSP
23	CNV_WR_CLK_DP		
33	GND	32	CNV_RGI_DT
35	PCIE1_TxP0	34	CNV_RGI_RSP

Pin	Definition	Pin	Definition
37	PCIE1_TxN0	36	CNV_BRI_DT
39	GND	38	CLINK_RST#
41	PCIE1_RxP0	40	CLINK_DATA
43	PCIE1_RxN0	42	CLINK_CLK
45	GND	44	CNV_BLANKING
47	REFCLK1+	46	CNV_MFUART2_TXD
49	REFCLK1-	48	CNV_MFUART2_RXD
51	GND	50	SUSCLK_WIFI
53	CLK_REQ#	52	PCIE_RST#
55	PCIE_WAKE#	54	BT_DIS2#
57	GND	56	WIFI_DIS1#
59	CNV_WT_1_DN	58	+3.3V
61	CNV_WT_1_DP	60	+3.3V
63	GND	62	+3.3V
65	CNV_WT_0_DN	64	NC
67	CNV_WT_0_DP	66	PCIE_RST#
69	GND	68	NC
71	CNV_WT_CLK_DN	70	NC
73	CNV_WT_CLK_DP	72	+3.3V
75	GND	74	+3.3V

2.3.18 COM1 , COM2 , COM3

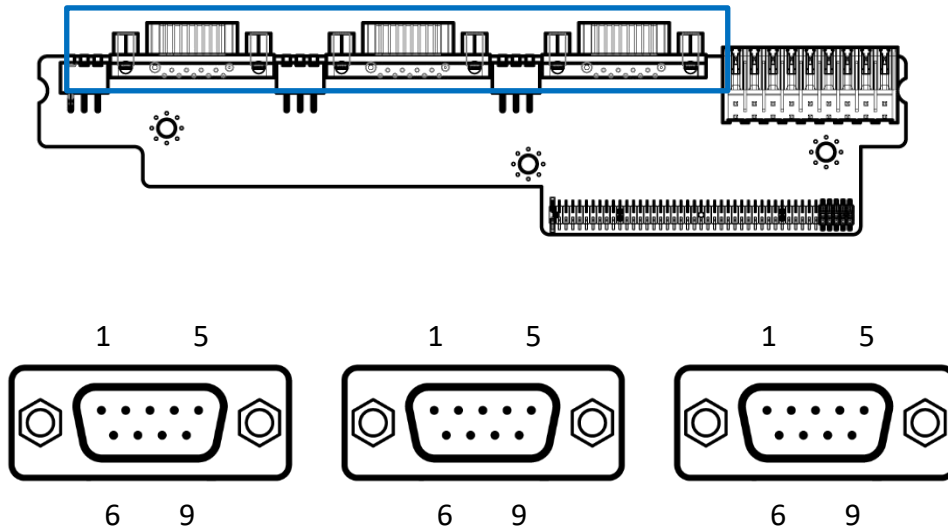

RS232 / RS422 / RS485 Connector Type: 9-pin D-Sub

Pin	RS232 Definition	RS422 / 485 Full Duplex Definition	RS485 Half Duplex Definition
1	DCD#	TX-	DATA-
2	RxD	TX+	DATA+
3	TxD	RX+	
4	DTR#	RX-	
5	GND	GND	GND
6	DSR#		
7	RTS#		
8	CTS#		
9	RI#		

2.3.19 Digital Input / Output Connector Type: Terminal Block 2x9 18-pin, 3.5mm pitch

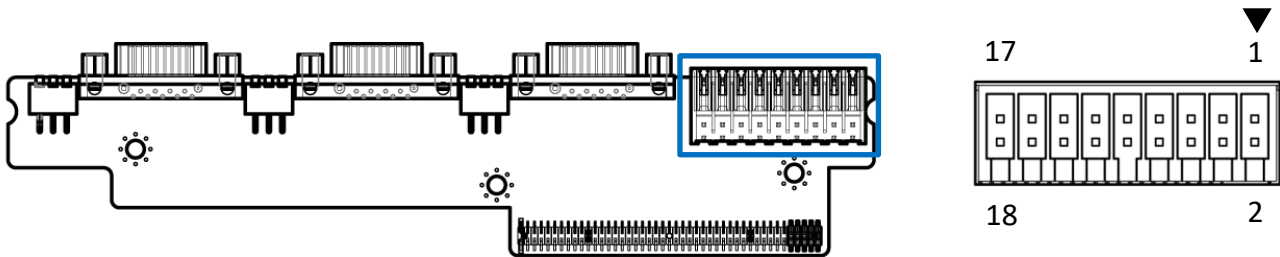

DIO

Pin	Definition	Pin	Definition
1	DIN1	2	DOUT1
3	DIN2	4	DOUT2
5	DIN3	6	DOUT3
7	DIN4	8	DOUT4
9	DIN5	10	DOUT5
11	DIN6	12	DOUT6
13	DIN7	14	DOUT7
15	DIN8	16	DOUT8
17	DC power input (+9V~+24V)	18	GND

2.3.20 CAN BUS Connector

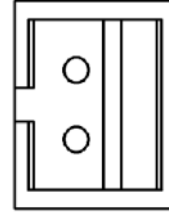
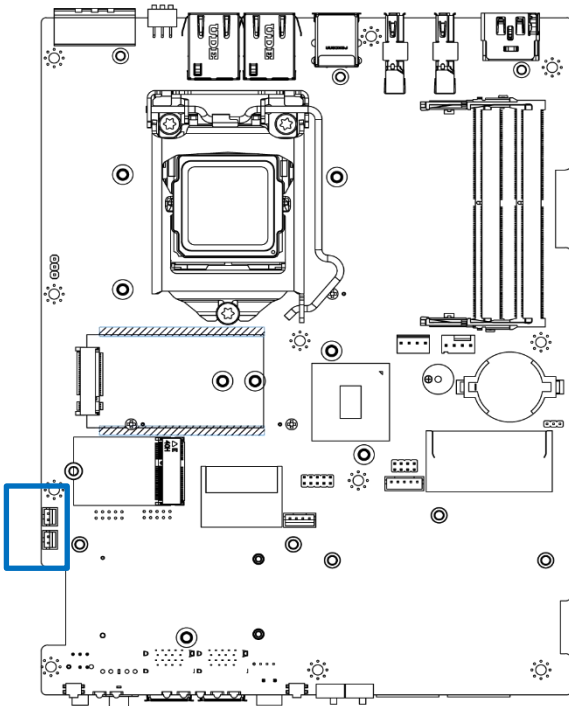

CAN BUS 1-2

Pin	Definition
1	CAN_L
2	CAN_H

Chapter 3

System Setup

3.1 Set torque force to 3.5 kgf-cm to execute all the screwing and unscrewing.

3.2 Removing chassis bottom cover

**WARNING**

In order to prevent electric shock or system damage, before removing the chassis cover, must turn off power and disconnect the unit from power source.

1. Turn the system upside down. Unscrew the 6 screws (M3x5L) on the bottom cover.



2. Now you can remove the bottom cover.



3.3 Removing chassis top cover

1. Unscrew the four screws (M3x5L) highlighted below.

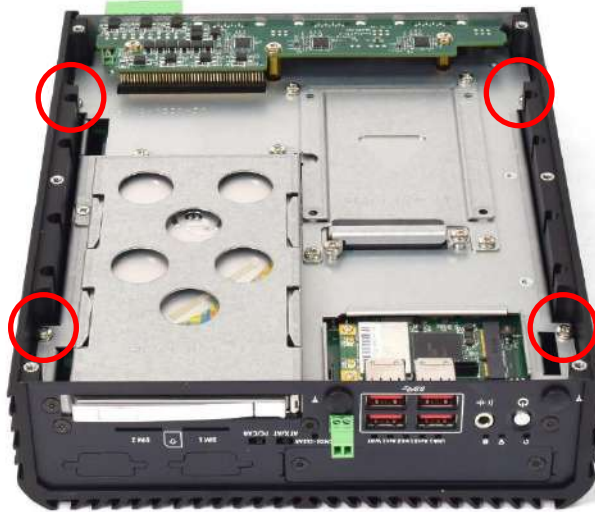

2. Hold the body of the system and lift it vertically away from the top cover.



3. Top cover separated from the system body.



3.4 Installing SODIMM

1. Place the system body with SODIMM socket facing upward. Two SODIMM sockets are available for RCO-3000-CML Series on the top side.



2. Insert memory module from 45 degree direction.



3. Press the memory module vertically downward until you hear the “click” sound. Make sure the memory module is firmly in place.

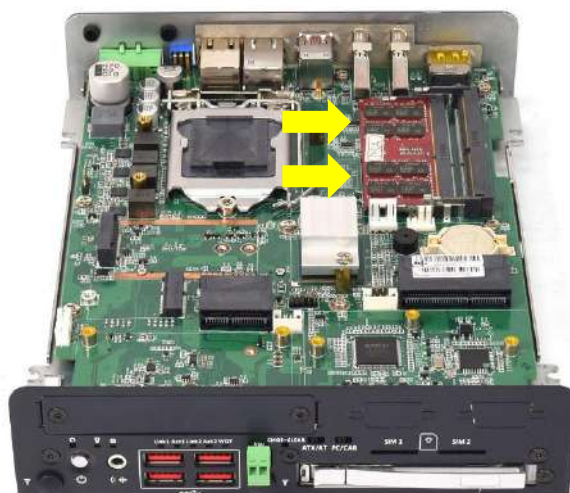

3.5 Installing CPU

1. CPU socket is located on the top side.

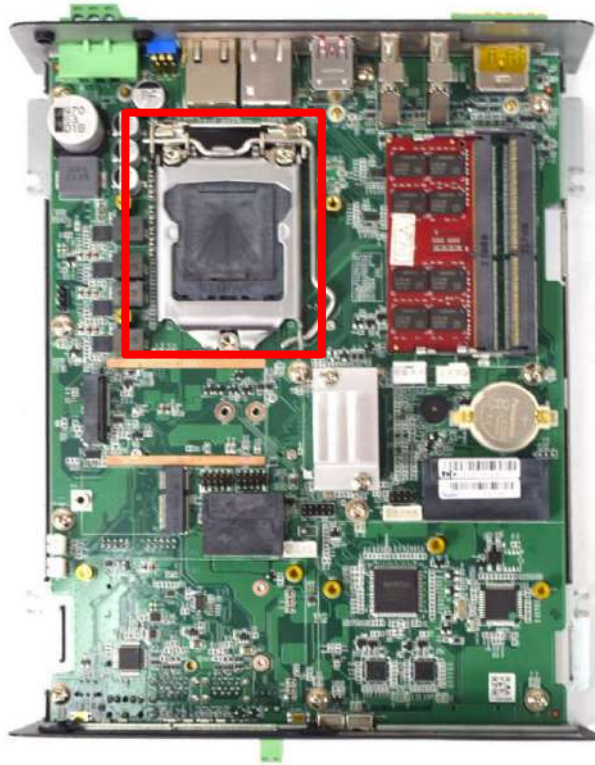

2. Press down the CPU socket lever in order to open the socket cover.

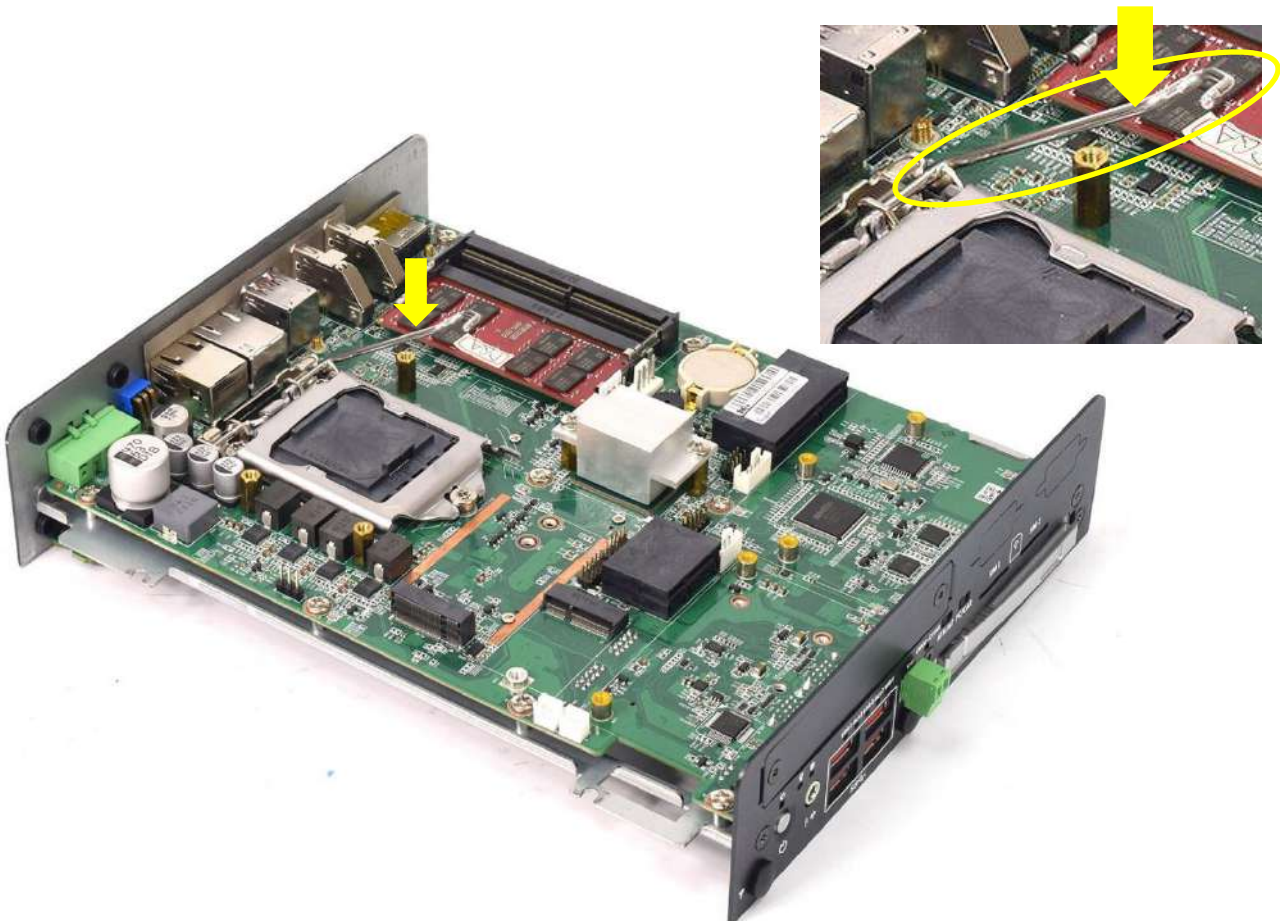

3. Remove the CPU protective cover.

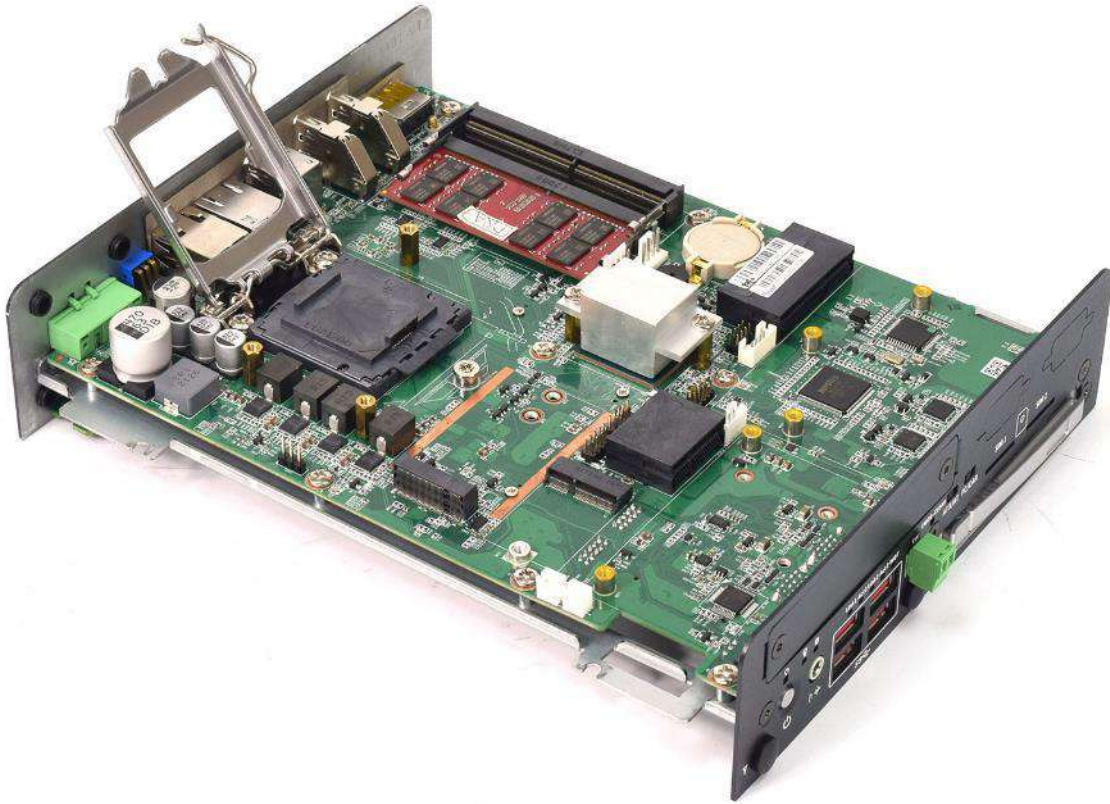

4. Insert CPU gently.

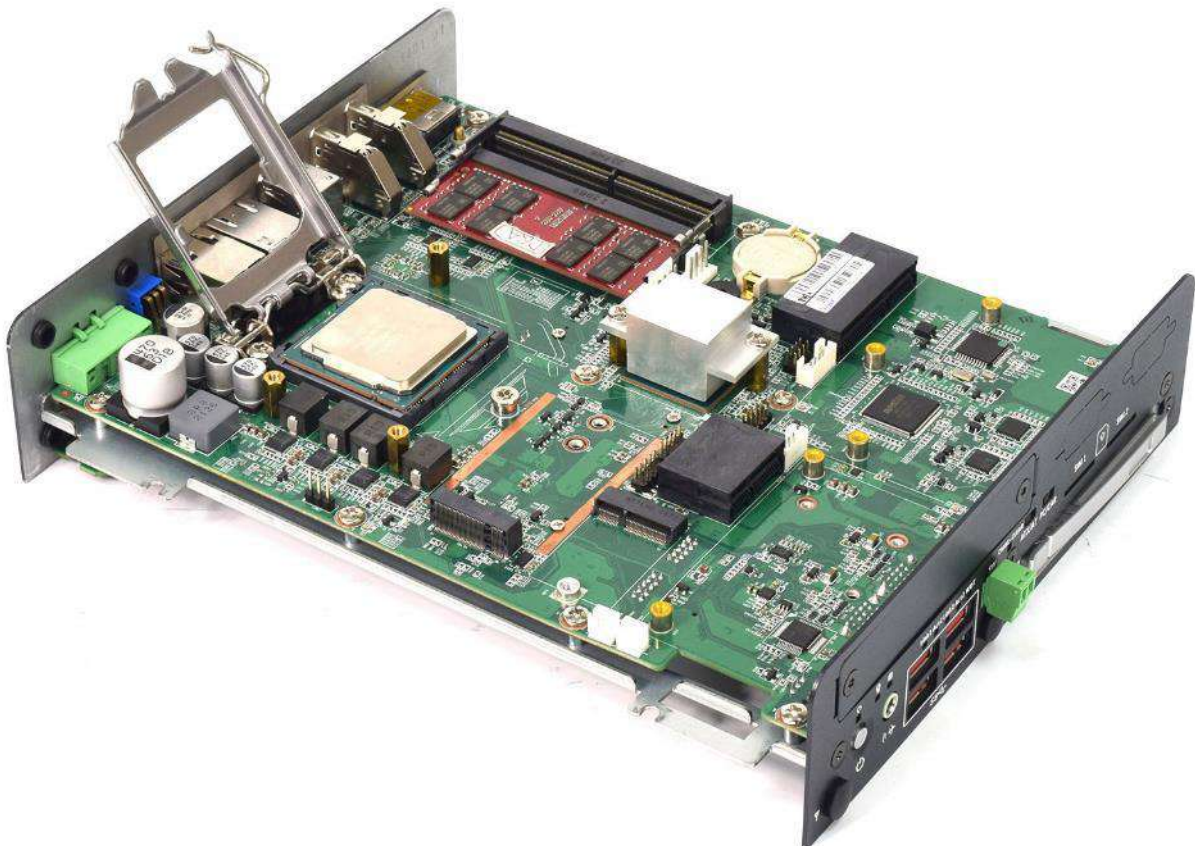

5. Press down the lever again to hold the socket cover.

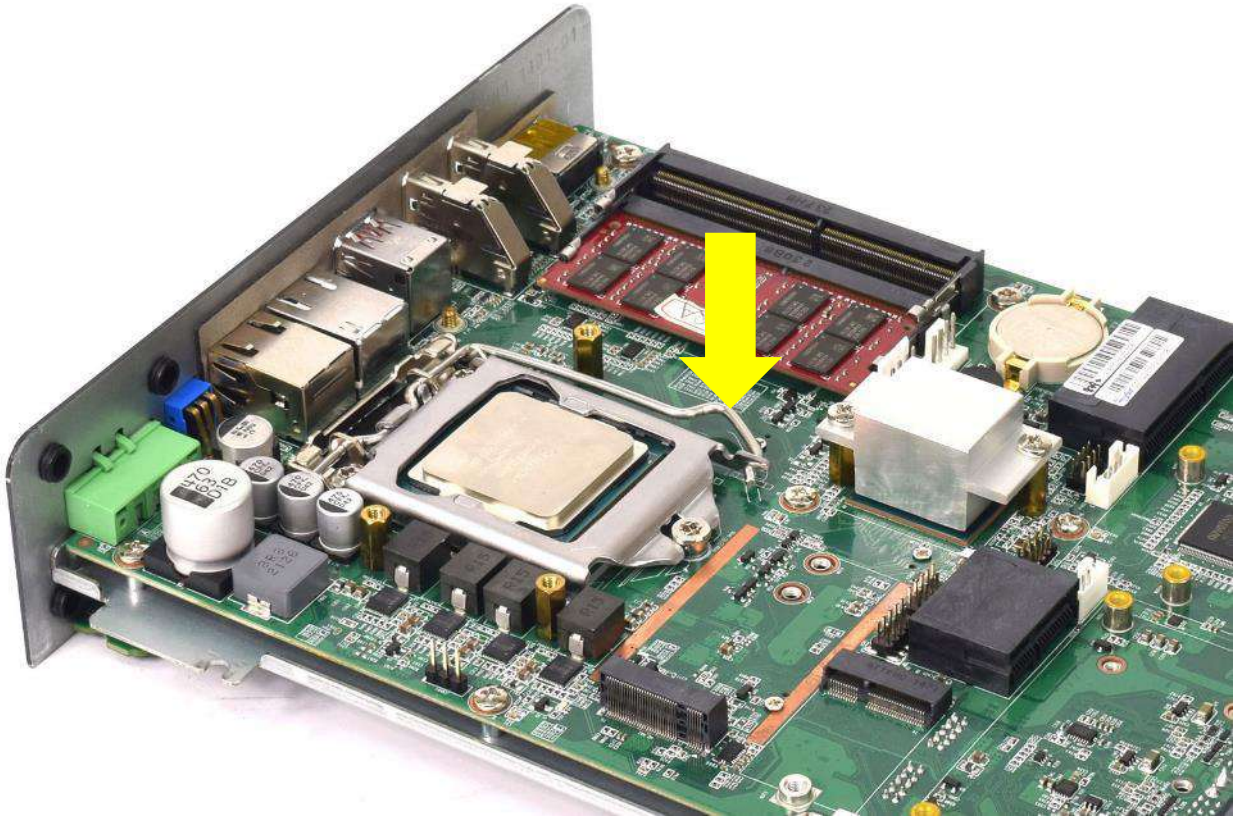

6. Paste thermal pad on the CPU.

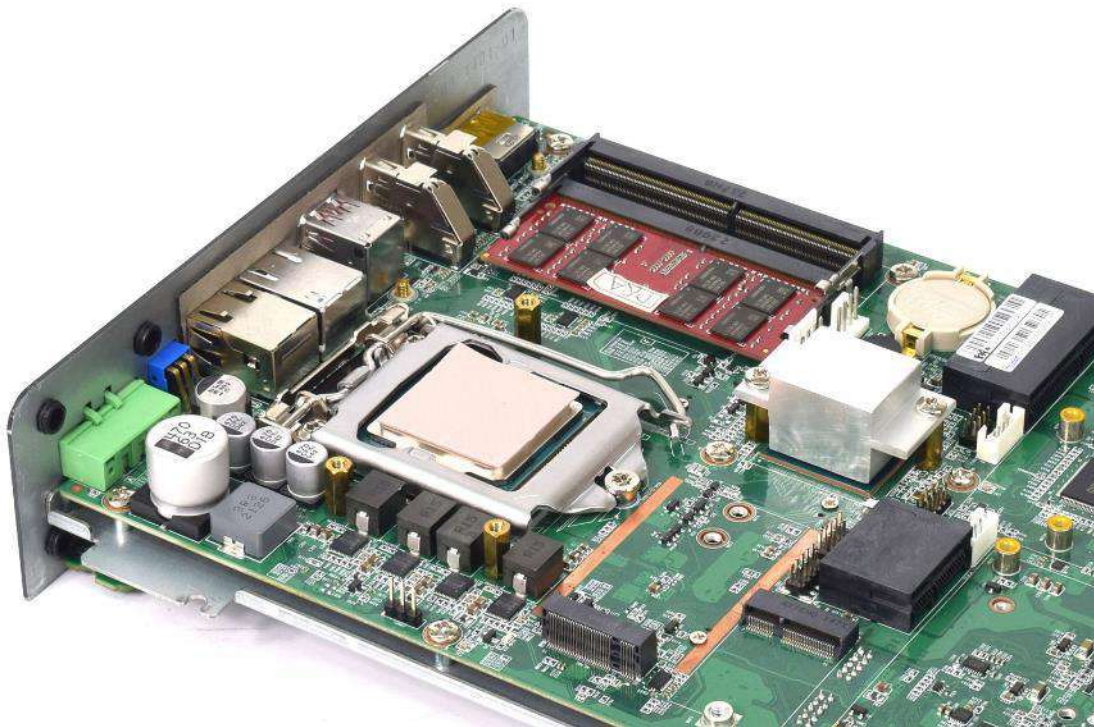

- Place the designated heat block onto the CPU with thermal pad. Lock the heat block with three screws (M3x5L). The three screws will safely lock the heat block onto the three copper studs that are screwed into the motherboard.

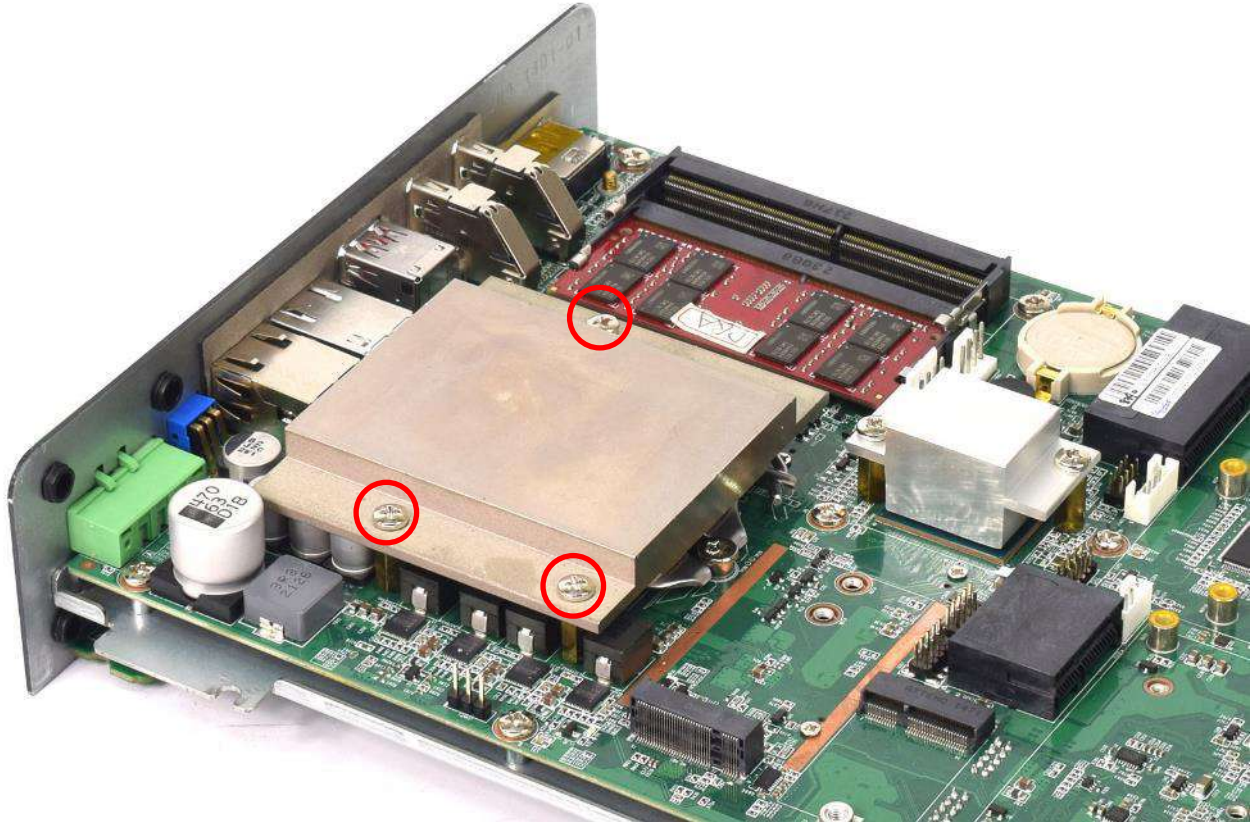

- Paste the thermal pad onto the installed heat block.

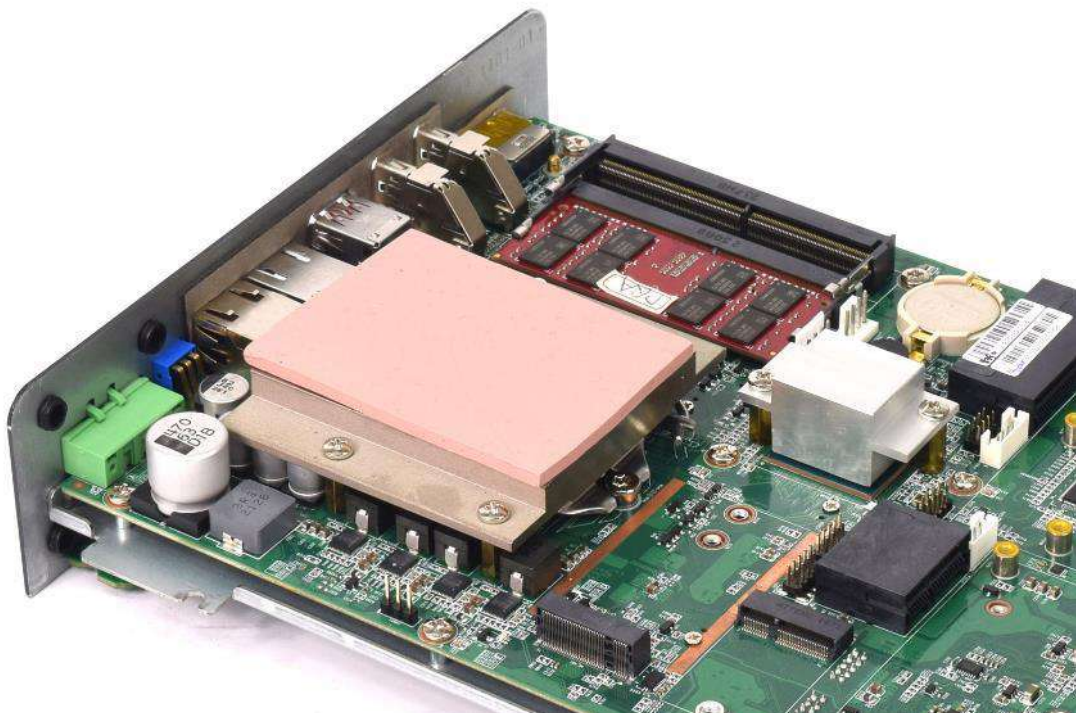

9. Installation complete.

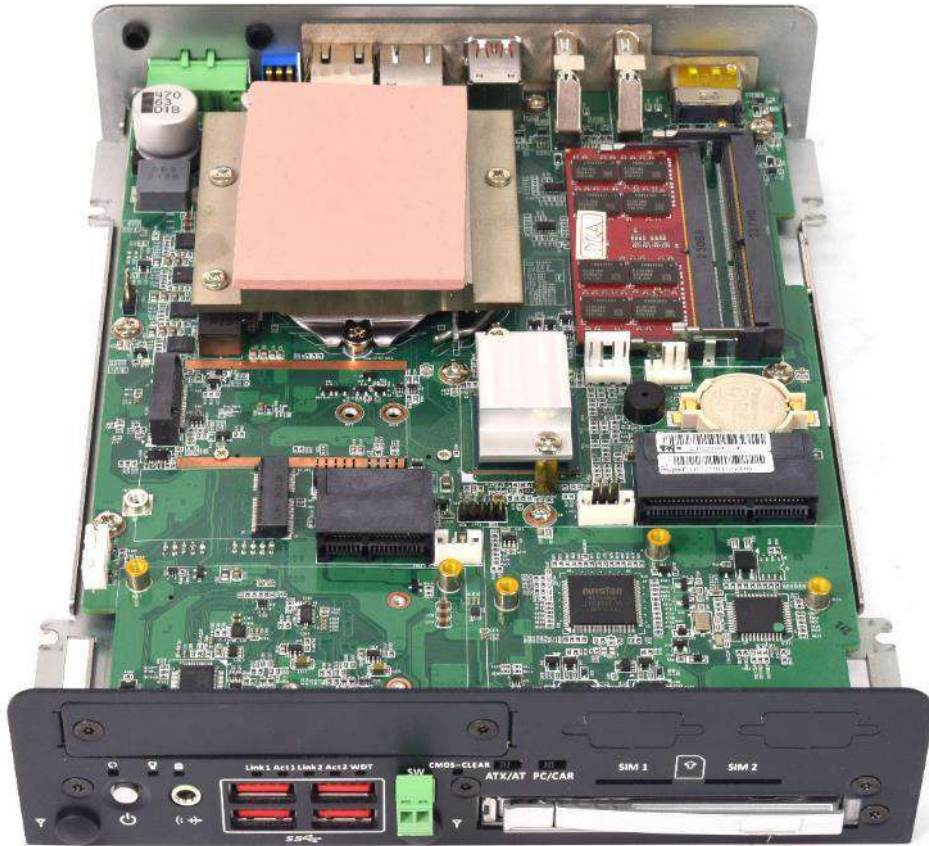

3.6 Installing mini PCIe card / mSATA / M.2

1. One mini PCIe slots are available for RCO-3000-CML series. The mini PCIe support mSATA.



2. Insert mini PCIe card from 45 degree direction.
Press the mini PCIe card down and lock it with one screws (M2x4L).



3.7 Installing antenna

1. Three antenna holes are available for RCO-3000-CML series on the rear panel and two holes are on the front panel.

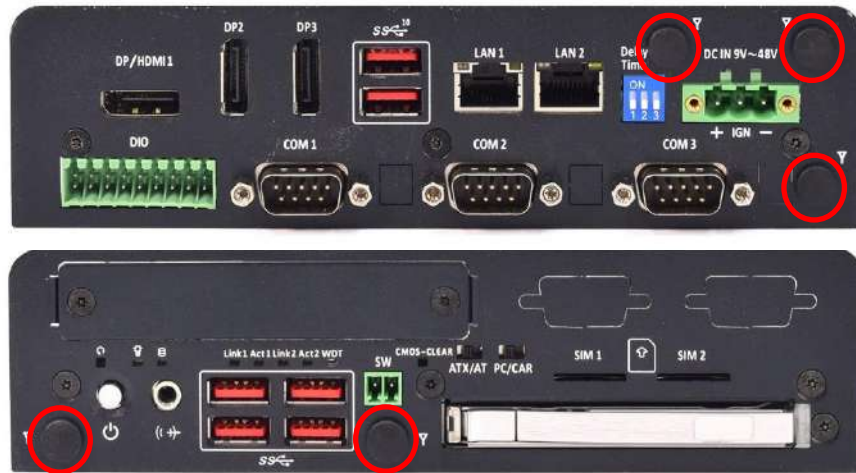

2. Remove antenna hole cover on the system panel.



3. Have antenna jack penetrate through the hole.
Put on washer and fasten the nut with antenna jack



4. Assemble the antenna and antenna jack together.



5. Attach the RF connector at the cable-end onto the communication module.



3.8 Assembly chassis top cover

1. Place the top cover upside down as shown below.



2. Ensure thermal pad is in place on both the CPU thermal block and PCH thermal block.

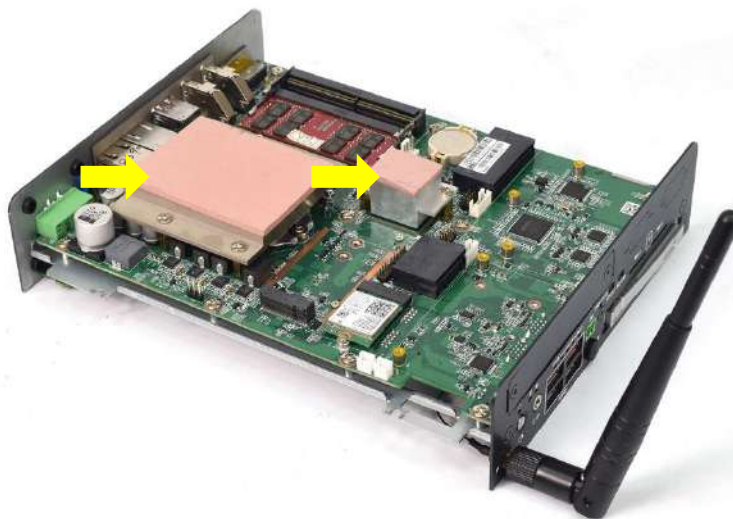

3. Hold the system body and slide the front/rear panel into the slide rail on the top cover.



4. Push the system body down until it is firmly in place.



5. Fasten the four screws (M3x5L) to lock the system body with top cover.

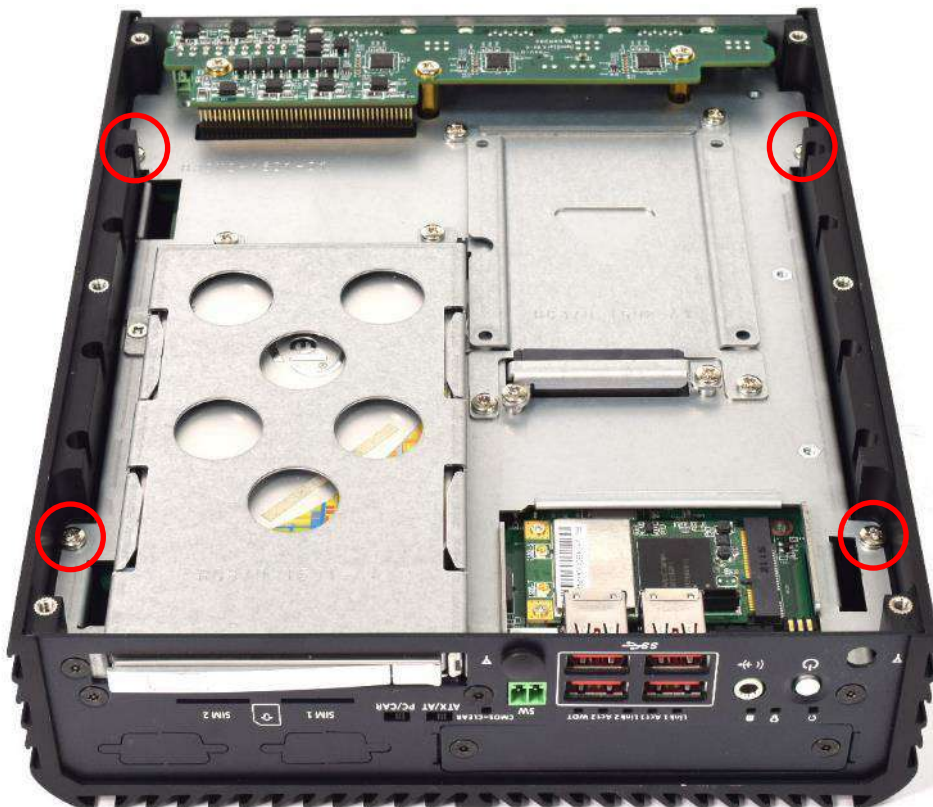

3.9 Installing HDD on internal SATA HDD bay

1. One internal SATA HDD bays are available for RCO-3000-CML series.

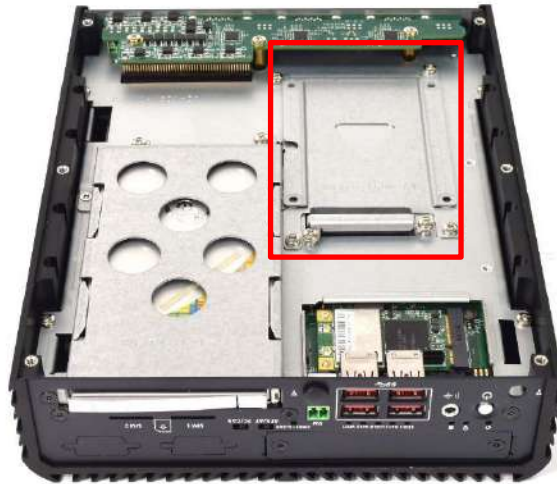

2. Unscrew the four screws (M3x5L) to remove the internal SATA HDD bay.

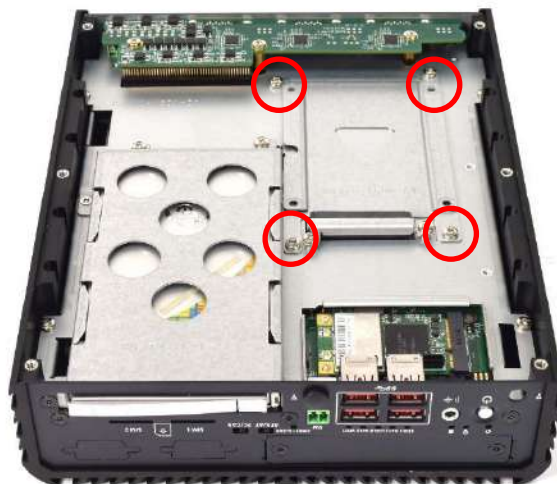

3. Lock the 2.5" HDD with HDD bracket using four screws (M3x4L).

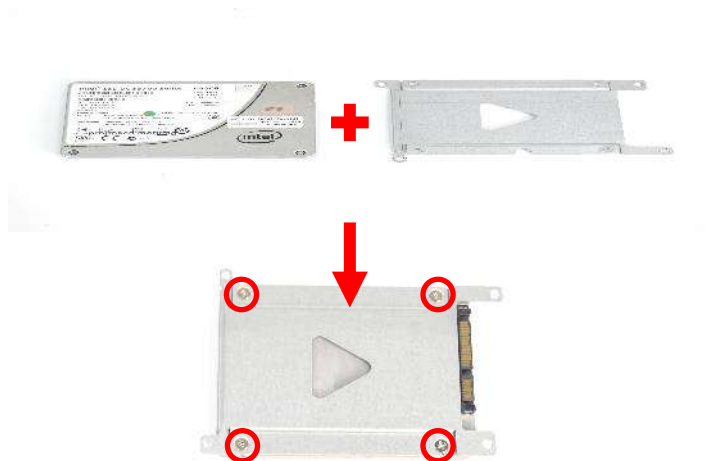

4. Install the HDD bracket following the direction below.

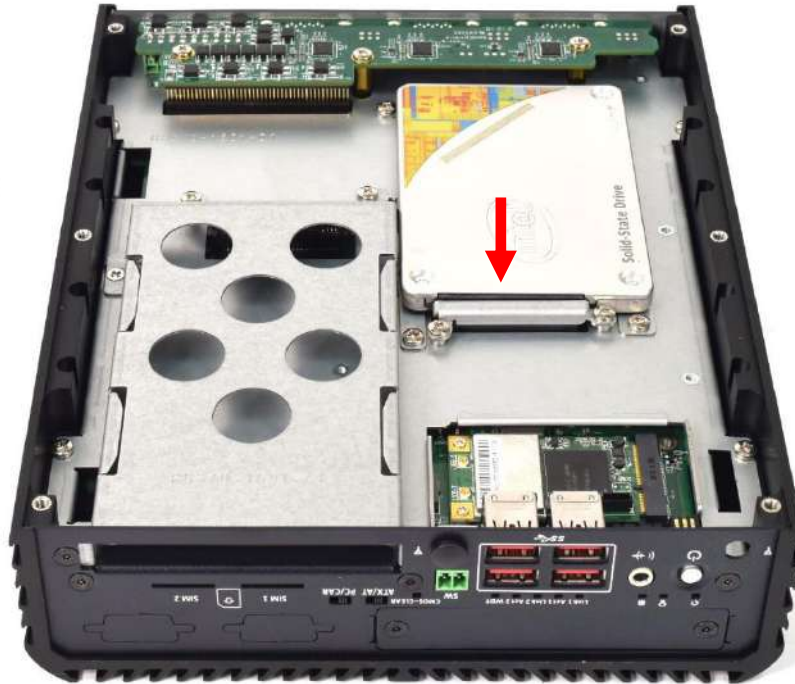

5. Fasten the four screws to lock the internal HDD bracket.

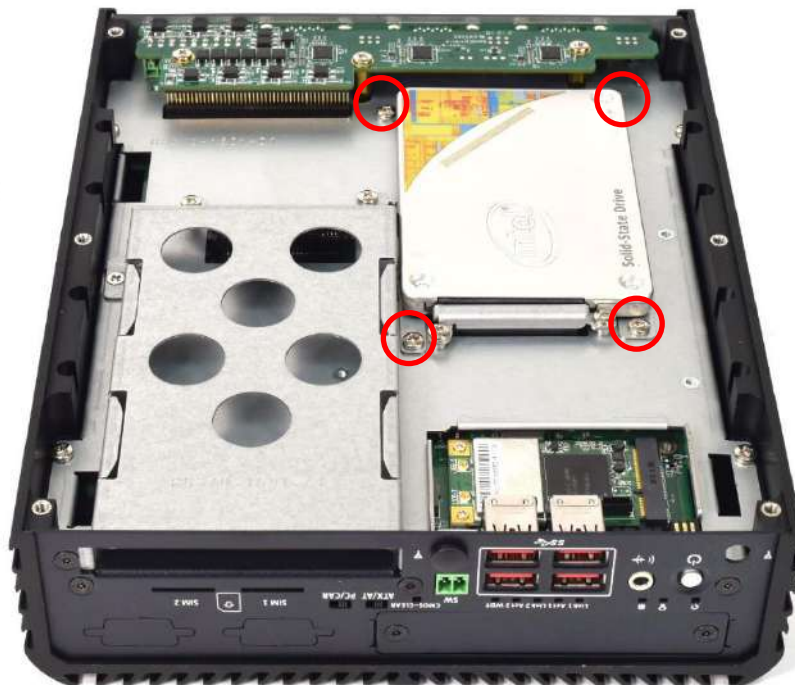

3.10 Installing HDD on removable SATA HDD tray

1. One removable SATA HDD tray available for RCO-3000-CML Series.
2. Open the tray lock (red circle), and remove the tray.



3. Unlock the drive lock and insert the HDD/SSD.

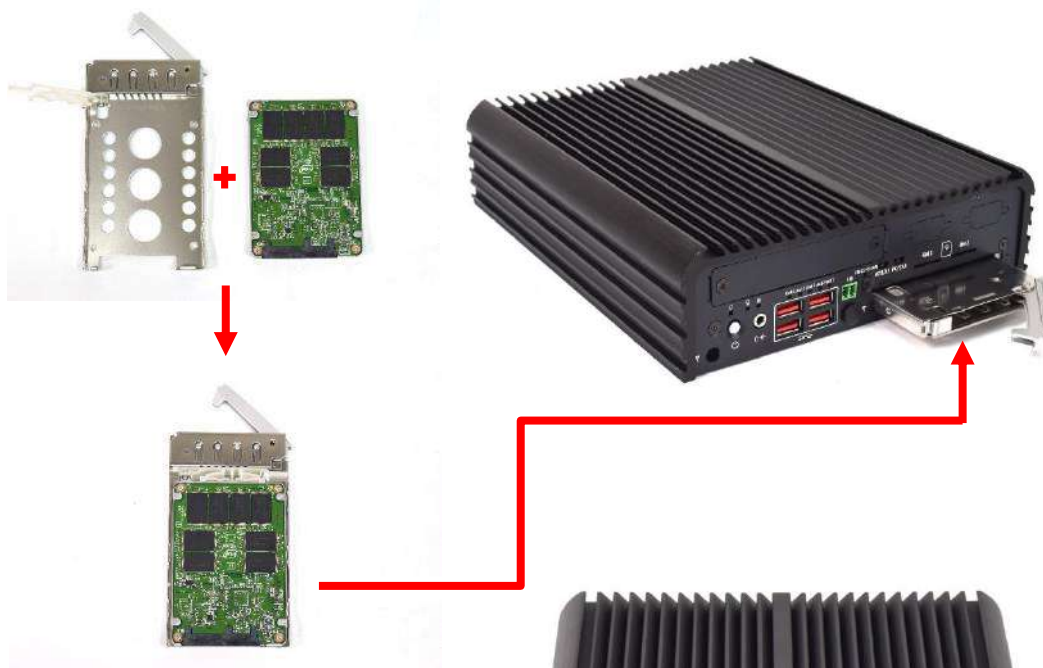

4. Slide the HDD tray back and close the tray lock.



3.11 Assemble chassis bottom cover

1. Place the bottom cover according to the below direction and make sure the rail is facing inside the system.



2. Lock the bottom cover with the six screws (M3x5L).



3.12 Installing SIM card

1. Insert SIM card into the socket.



2. Please note that the installation of SIM cards has to match the installation of mini PCIe slots

SIM Card Socket Number	Matching Mini PCIe Slot
SIM 1	MINIPCE1
SIM 2	M.2 B Key Socket

3.13 Installing wall mount kit

1. Wall mount kit is available for RCO-3000-CML series included in the standard package.



2. Place the system upside down so you can see the bottom cover. The highlighted screw holes below will be used.



3. Lock the wall mount kit with eight screws (M3x5L, Nylok).



3.14 Installing DIN rail holder

1. Din rail holder is available for RCO-3000-CML series as optional accessories.



2. Place the system upside down so you can see the bottom cover with two screw holes for din rail holder.

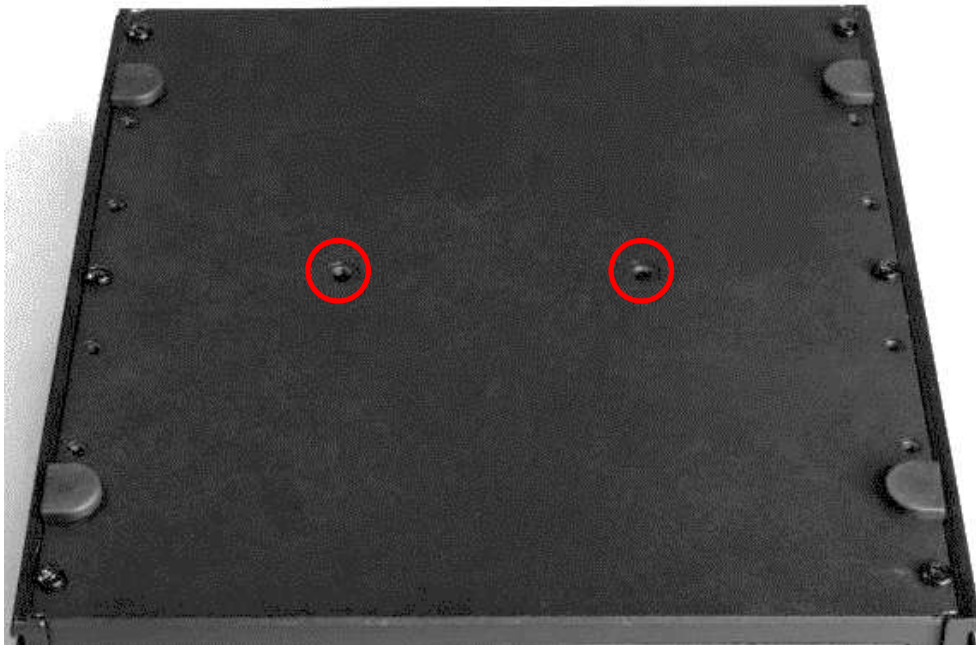

3. Place the din rail holder on top of the bottom cover and lock it with two screws (M4x5L, Nylok).



Chapter 4

BIOS Setup

4.1 BIOS Introduction

The BIOS provides an interface to modify the configuration. When the battery is removed, all the parameters will be reset.

BIOS Setup

Power on the embedded system and by pressing immediately allows you to enter the setup screens. If the message disappears before you respond and you still wish to enter the Setup, restart the system by turning it OFF and ON or pressing the RESET button.

You may also restart the system by simultaneously pressing <Ctrl>, <Alt>, and <Delete> keys.

Control Keys	
<→> <←>	Select Screen
<↑> <↓>	Select Item
<Enter>	Select
<Page Up/+>	Increases the numeric value or makes changes
<Page Down/->	Decreases the numeric value or makes changes
<F1>	General Help
<F2>	Previous Value
<F3>	Load Optimized Defaults
<F4>	Save Configuration and Exit
<Tab>	Select Setup Fields
<Esc>	Exit BIOS Setup

Main Setup

The main menu lists the setup functions you can make changes to. You can use the arrow keys (↑↓) to select the item. The on-line description of the highlighted setup function is displayed at the bottom of the screen.

General Help <F1>

The BIOS setup program provides a General Help screen. You can call up this screen from any menu by simply pressing <F1>. The Help screen lists the appropriate keys to use and the possible selections for the highlighted item. Press <Esc> to exit the Help screen.

4.2 Main Setup

Press to enter BIOS CMOS Setup Utility. The Main setup screen is showed as following when the setup utility is entered. System Date/Time is set up in the Main Menu.

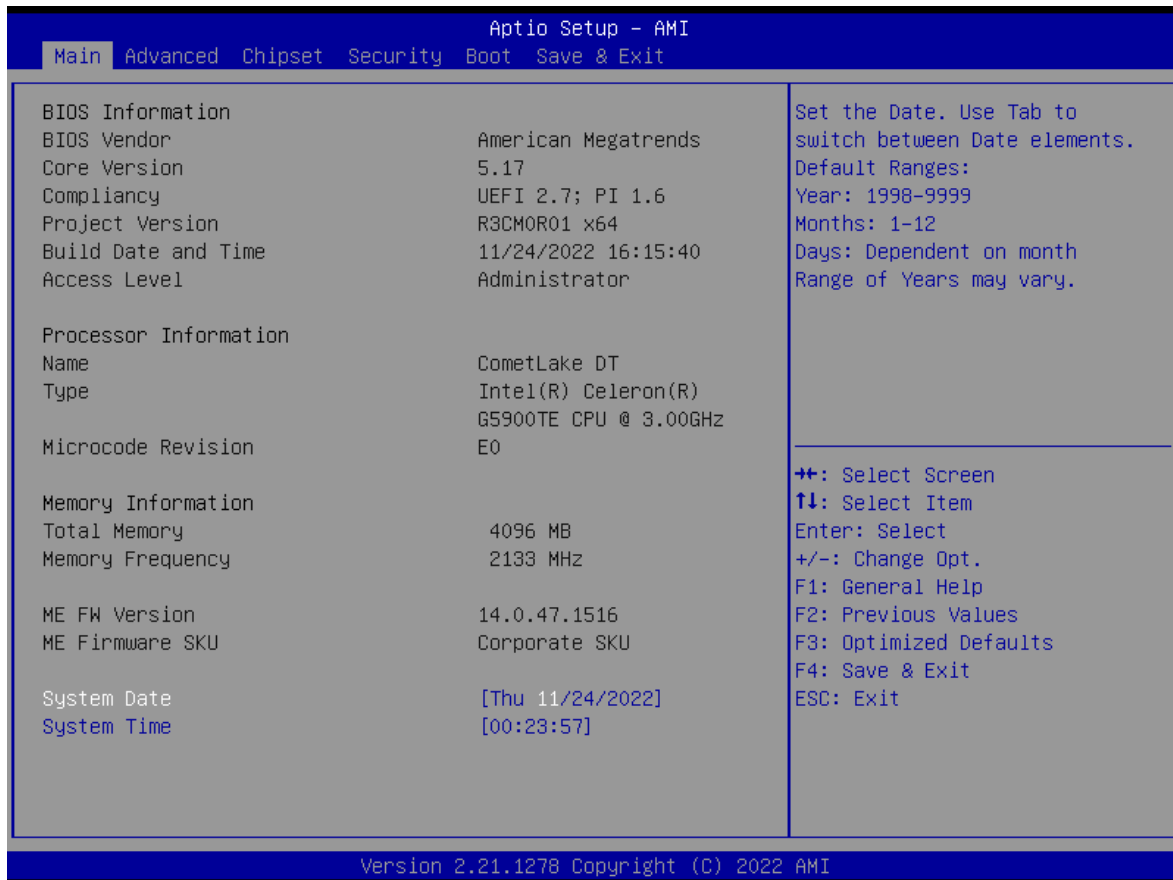

■ System Date

Set the system date. Please use <Tab> to switch between data elements.

■ System Time

Set the system time. Please use <Tab> to switch between time elements.

4.3 Advanced Setup

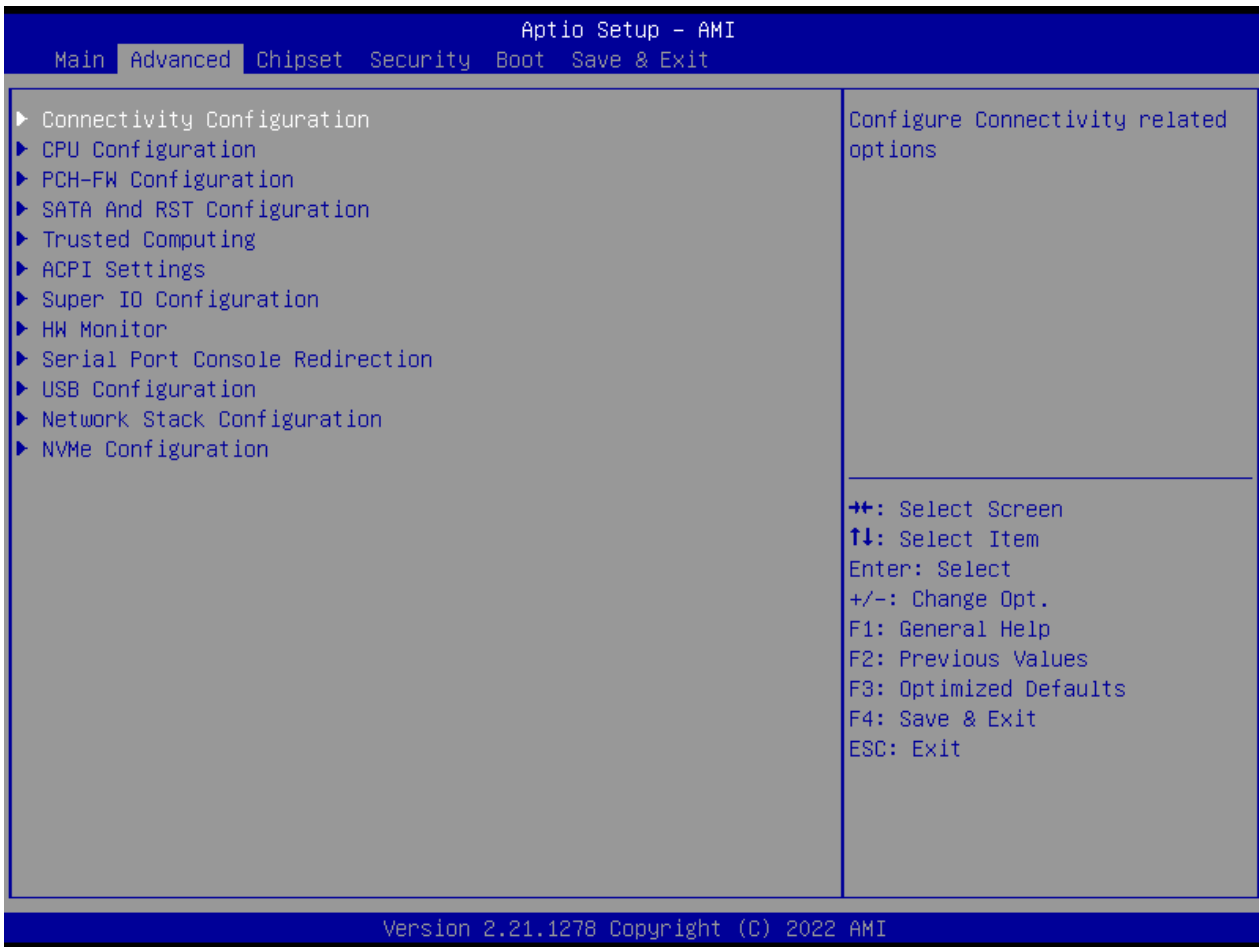

4.3.1 Connectivity Configuration



Item	Options	Description
CNVi Mode	Disable Integrated, Auto Detection [Default]	This option configures Connectivity. [Auto Detection] means that if Discrete solution is discovered it will be enabled by default. Otherwise Integrated solution (CNVi) will be enabled; [Disable Integrated] disables Integrated Solution. NOTE: When CNVi is present, the GPIO pins that are used for radio interface cannot be assigned to the other native function.
BT Core	Enabled [Default] , Disabled	This is an option intended to Enable/Disable BT Core in CNVi.

4.3.2 CPU Configuration

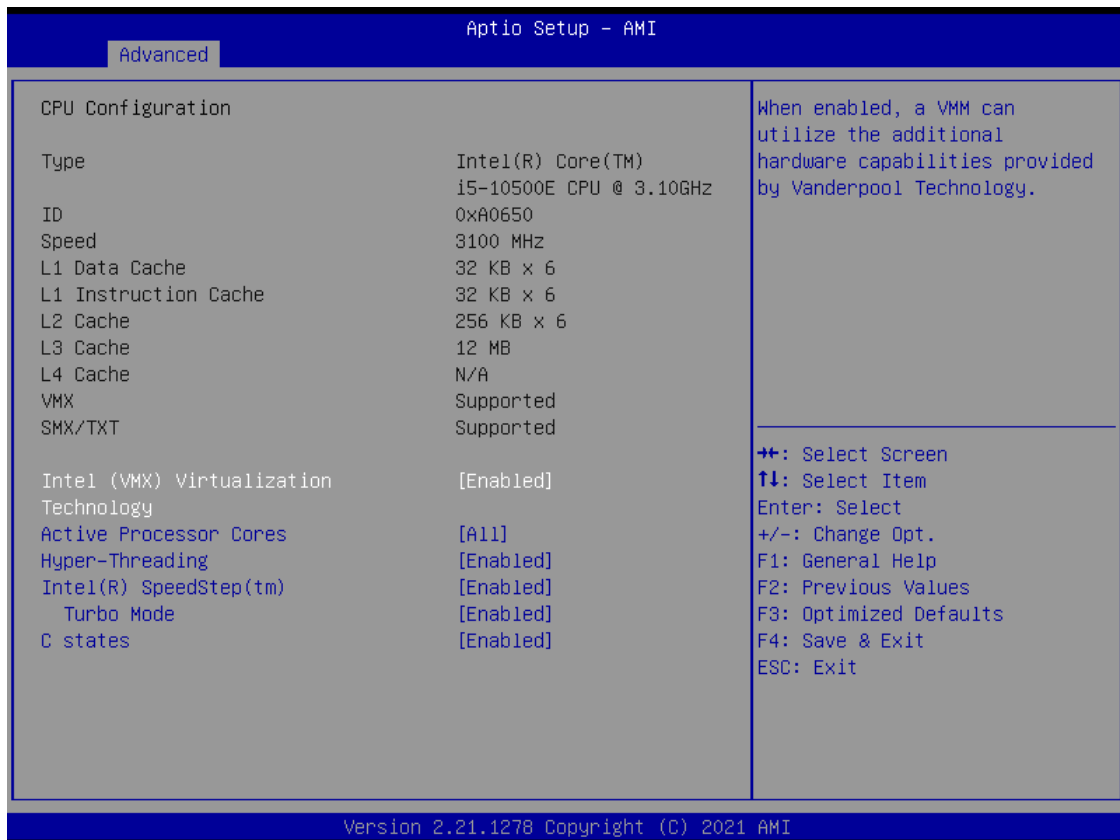

Item	Options	Description
Intel (VMX) Virtualization Technology	Disabled, Enabled[Default]	When enabled, a VMM can utilize the additional hardware capabilities provided by Virtualization Technology.
Active Processor Cores	All[Default] 1 2 3	Number of cores to enable in each processor package.
Hyper-Threading	Disabled, Enabled[Default]	Enabled for Windows XP and Linux (OS optimized for Hyper-Threading Technology) and Disabled for other OS (OS not optimized for Hyper-Threading Technology).
Intel SpeedStep	Disabled, Enabled[Default]	This item allows you to enable or disable the Intel SpeedStep.
Turbo Mode	Disabled, Enabled[Default]	This item allows you to enable or disable the Turbo Mode.
C states	Disabled, Enabled[Default]	Enable/Disable CPU Power Management. Allows CPU to go to C states when it's not 100% utilized.

4.3.3 PCH-FW Configuration

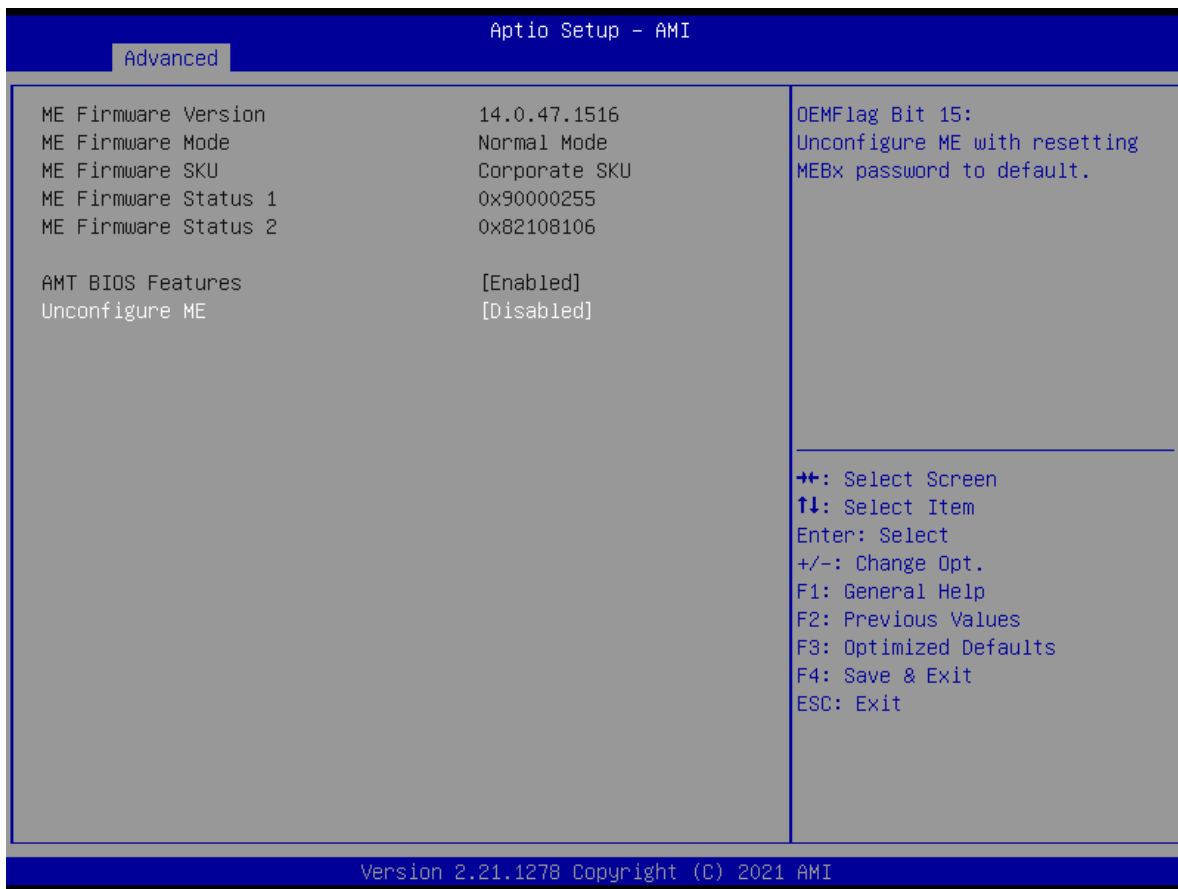

Item	Options	Description
AMT BIOS Features	Disabled, Enabled[Default]	When disabled AMT BIOS Features are no longer supported and user is no longer able to access MEBx Setup. Note:This option does not disable Manageability Features in FW.
Unconfigure ME	Disabled[Default], Enabled	OEMFlag Bit 15: Unconfigure ME with resetting MEBx password to default.

4.3.4 SATA and RST Configuration

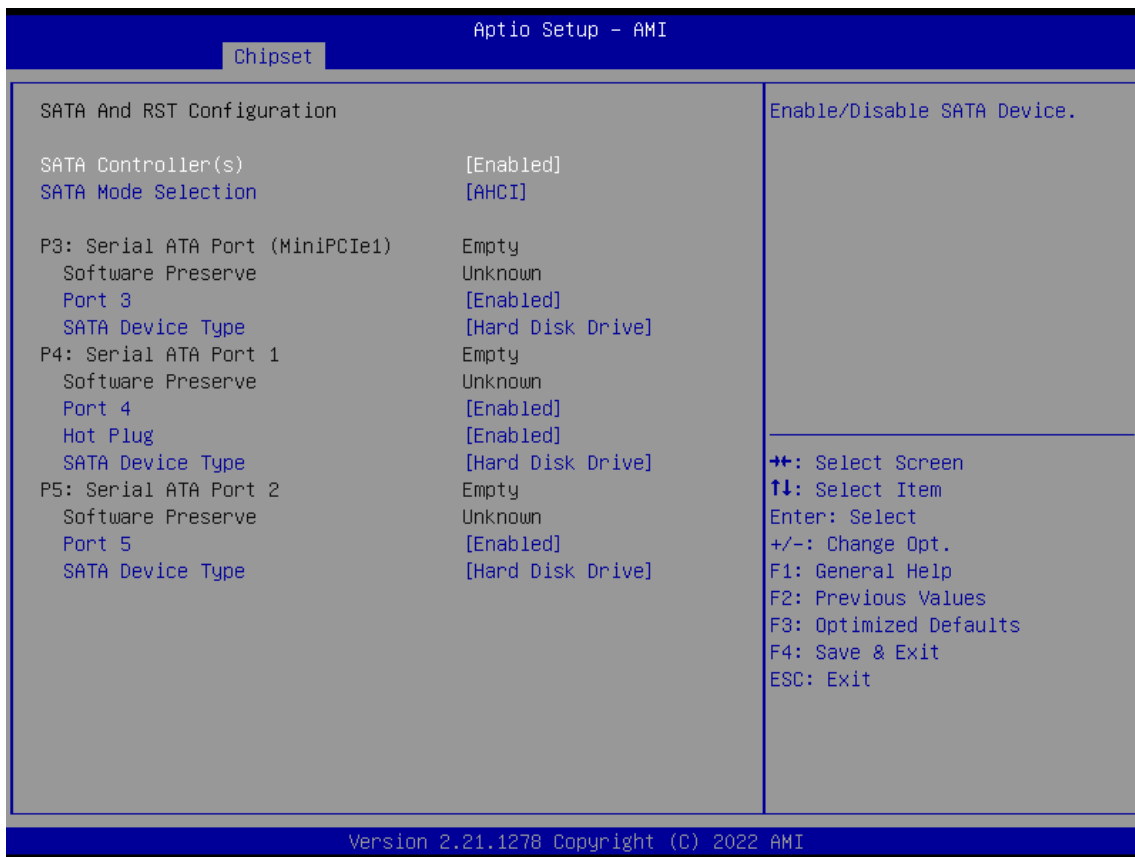

Item	Options	Description
SATA Controller(s)	Disabled, Enabled[Default]	Enable/Disable SATA Device.
SATA Mode Selection	AHCI[Default] , Intel RST Premium With Intel Optane System Acceleration	Determines how SATA controller(s) operate.
Port3 ~5	Disabled, Enabled[Default]	Enable/Disable SATA Port.
SATA Device Type	Hard Disk Drive[Default] , Solid State Drive	Identify the SATA port is connected to Solid State Drive or Hard Disk Drive.
Hot Plug	Disabled, Enabled[Default]	Designates this port as Hot Pluggable.

4.3.5 RST (UEFI RAID) Configuration

How to set the UEFI RAID:

1. When set to “Intel RST Premium With Intel Optane System Acceleration“, please save change reset system.

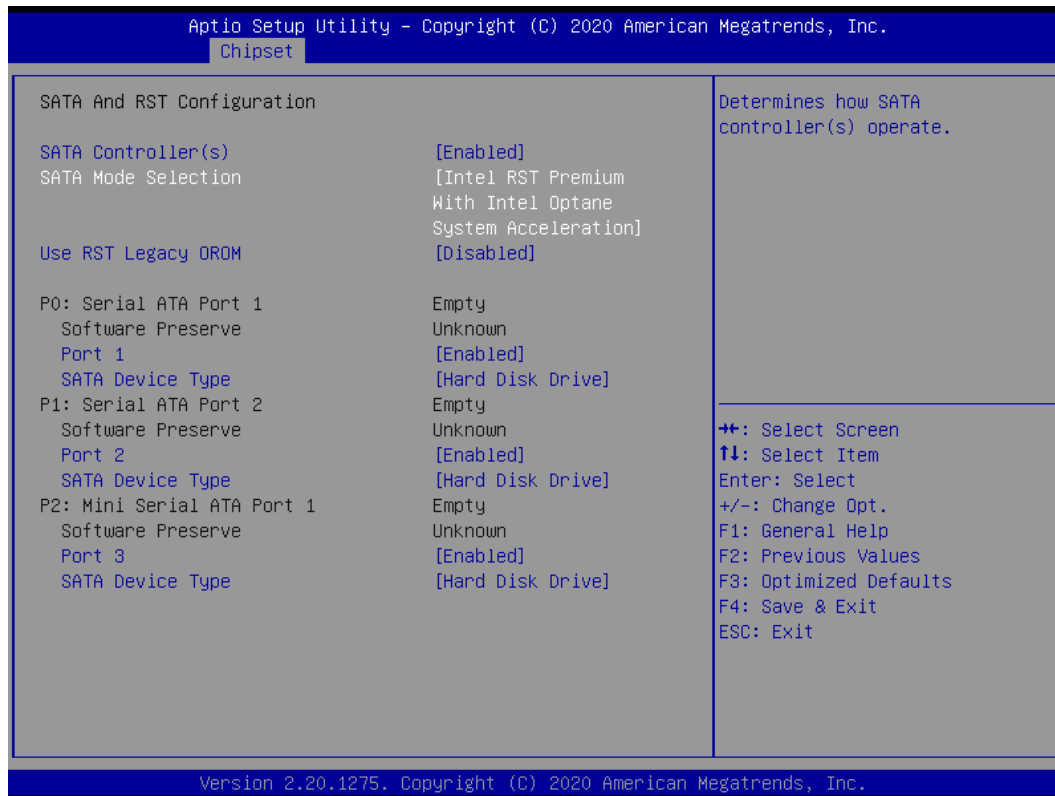

2. After reboot the system, please into BIOS utility and then will see “Intel (R) Rapid Storage Technology”

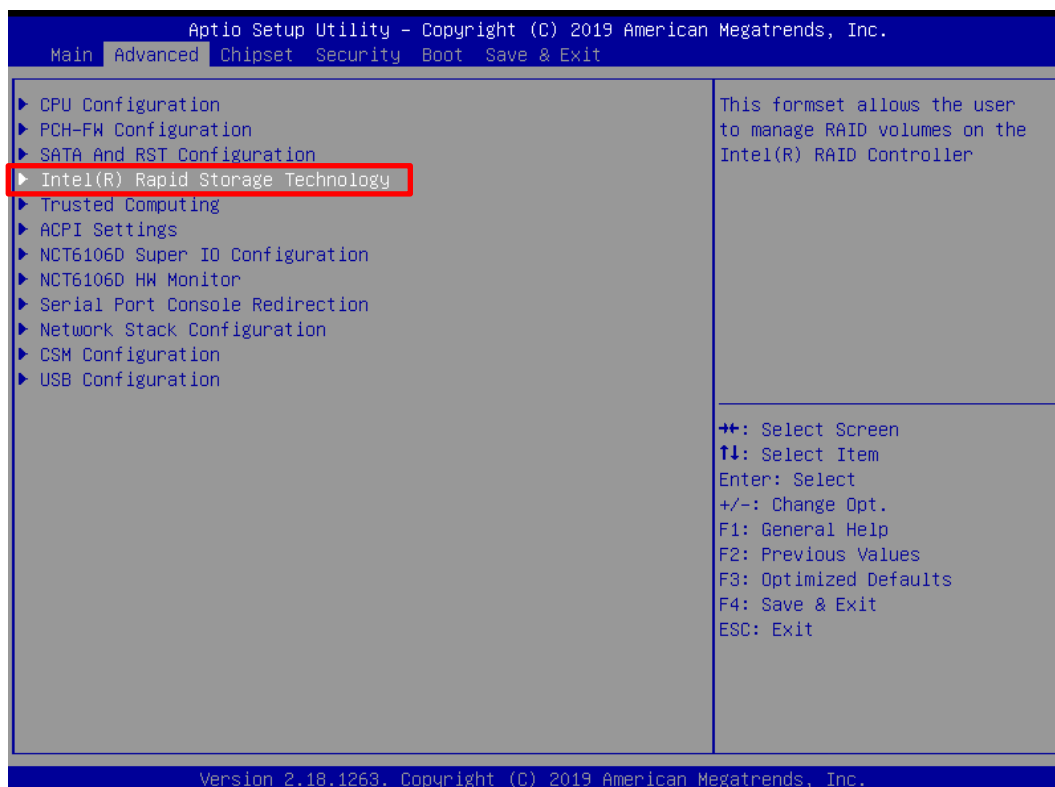

3. Into Intel(R) Rapid Storage Technology, and start create RAID volume.

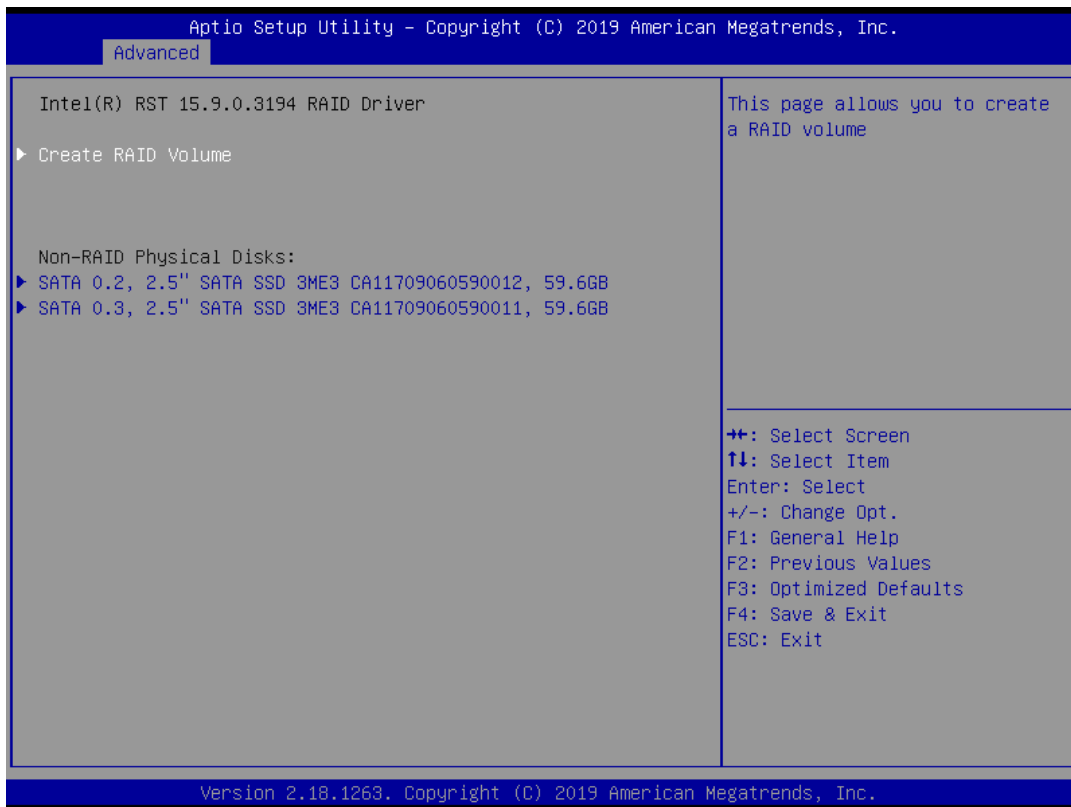

4. Start Create the RAID

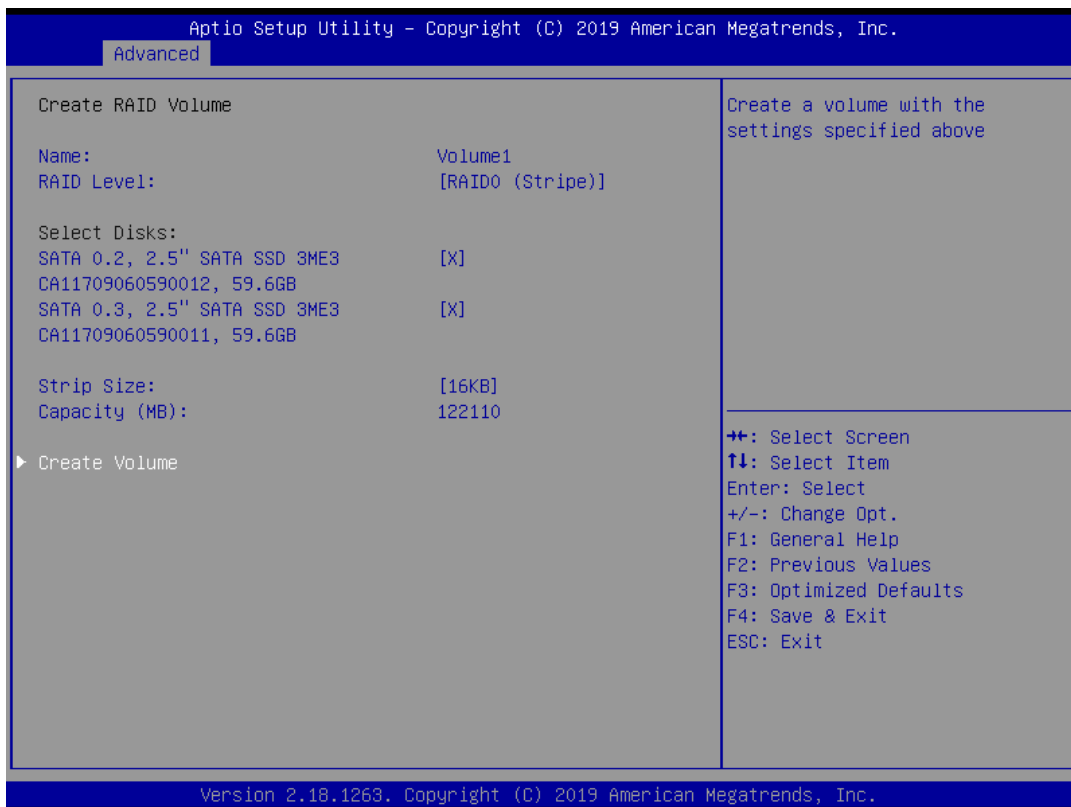

- Select Disk that you want to do the RAID
- Select [x]; No-Select []

4.3.6 Trusted Computing



Item	Options	Description
Security Device Support	Enabled, Disabled [Default] ,	Enable/Disable BIOS support for security device. O.S. will not show Security Device.TCG EFI protocol and INT1A interface will not be available.
Pending operation	None [Default] , TPM Clear	Schedule an Operation for the Security Device. NOTE: Your Computer will reboot during restart in order to change State of Security Device.

4.3.7 ACPI Settings

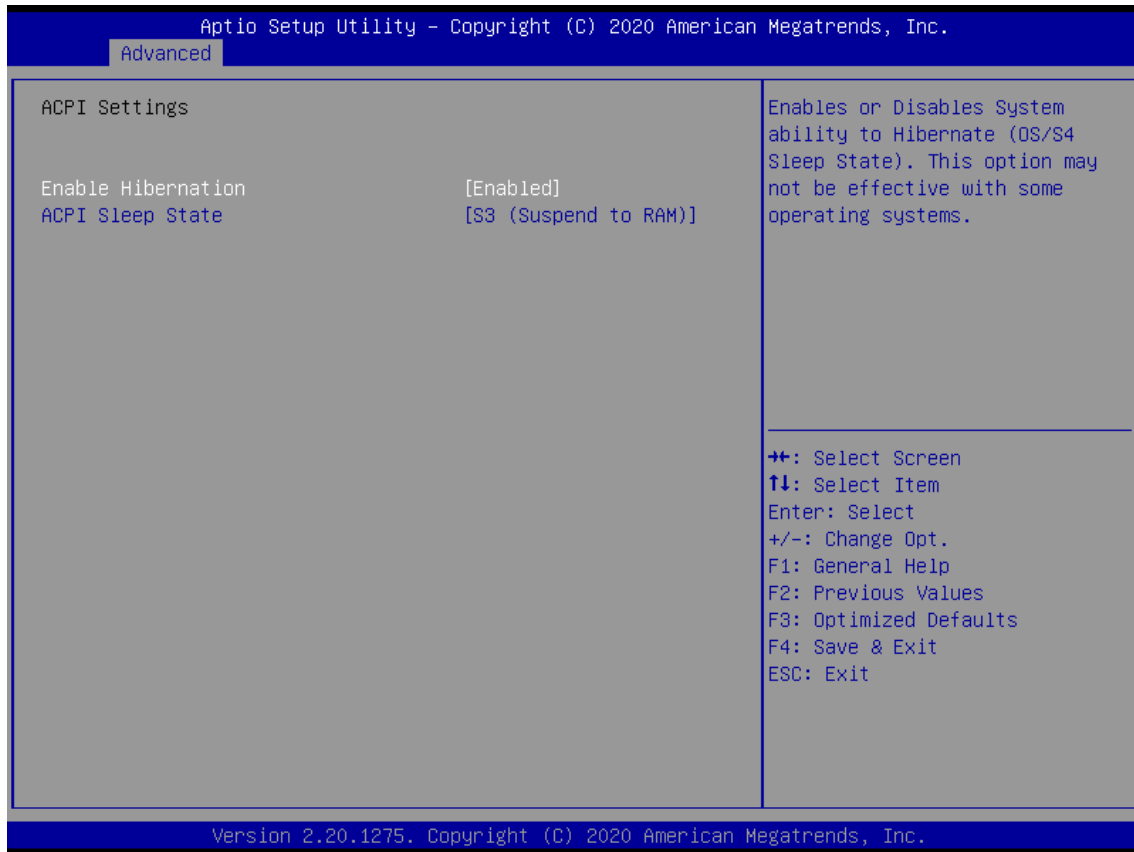

Item	Options	Description
Enable Hibernation	Disabled , Enabled [Default] ,	Enables or Disables System ability to Hibernate (OS/S4 Sleep State). This option may not be effective with some operating systems.
ACPI Sleep State	Suspend Disabled, S3 (Suspend to RAM) [Default]	Select the highest ACPI sleep state the system will enter when the SUSPEDN button is pressed.

4.3.8 Super IO Configuration

This setting allows you to select options for the Super IO Configuration, and change the value of the selected option.

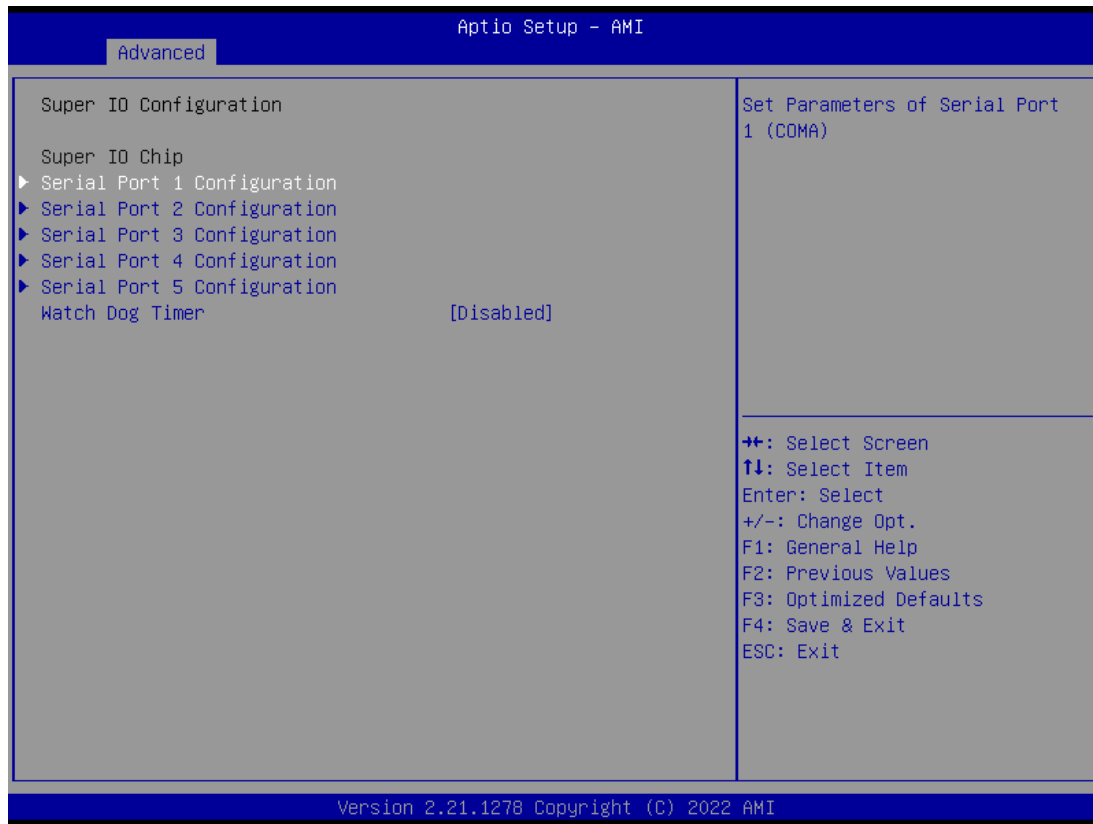

Item	Description
Serial Port 1 Configuration	Set Parameters of Serial Port 1 (COMA).
Serial Port 2 Configuration	Set Parameters of Serial Port 2 (COMB).
Serial Port 3 Configuration	Set Parameters of Serial Port 3 (COMC).
Serial Port 4 Configuration	Set Parameters of Serial Port 4 (COMD).
Serial Port 5 Configuration	Set Parameters of Serial Port 5 (COME).

Item	Options	Description
Watch Dog Timer	Disabled [Default] , Enabled	Enabled or Disabled Watch Dog Timer function.
Watch Dog Timer Count Mode	Second Mode [Default] , Minute Mode	Select Second Mode or Minute Mode.
Watch Dog Timer Time out Value	20~255(Second) [Default] , 1~255(Minute)	Watch Dog Timer Time out Value.

Serial Port 1 Configuration

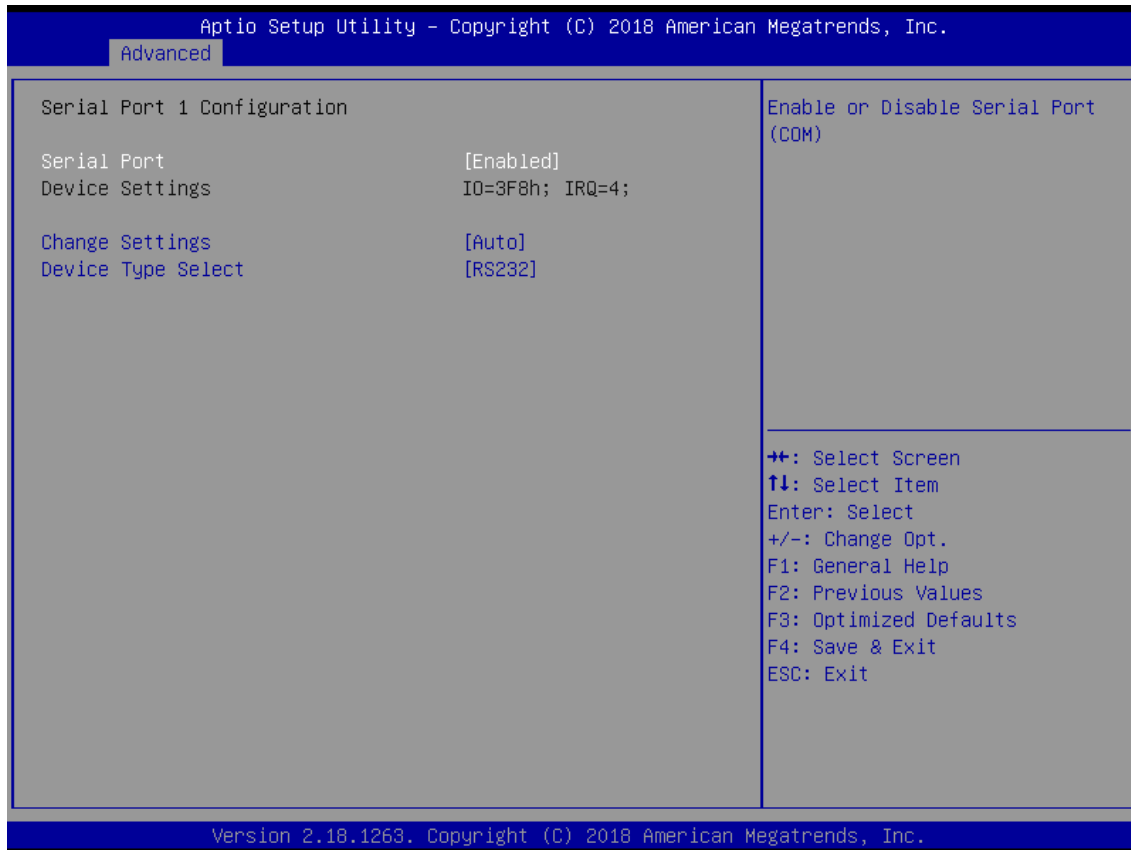

Item	Options	Description
Serial Port	Disabled, Enabled[Default]	Enable or Disable Serial Port (COM).
Change Settings	Auto[Default], IO=3F8h; IRQ=4; , IO=3F8h; IRQ=3,4,5,6,7,9,10,11,12; , IO=2F8h; IRQ=3,4,5,6,7,9,10,11,12;; IO=3E8h; IRQ=3,4,5,6,7,9,10,11,12;; IO=2E8h; IRQ=3,4,5,6,7,9,10,11,12;	This item allows you to change the address & IRQ settings of the specified serial port.
Device Type Select	UART 232[Default], UART 422, UART 485	Set the Serial Port to RS232 & RS422 & RS485
RS-485 Auto Flow Function	Disabled, Enabled[Default]	Enabled/Disabled RS485 Autoflow Function
RS-422/RS-485 Terminal Function	Disabled, Enabled[Default]	RS-422/RS-485 Terminal Function

Serial Port 2 Configuration

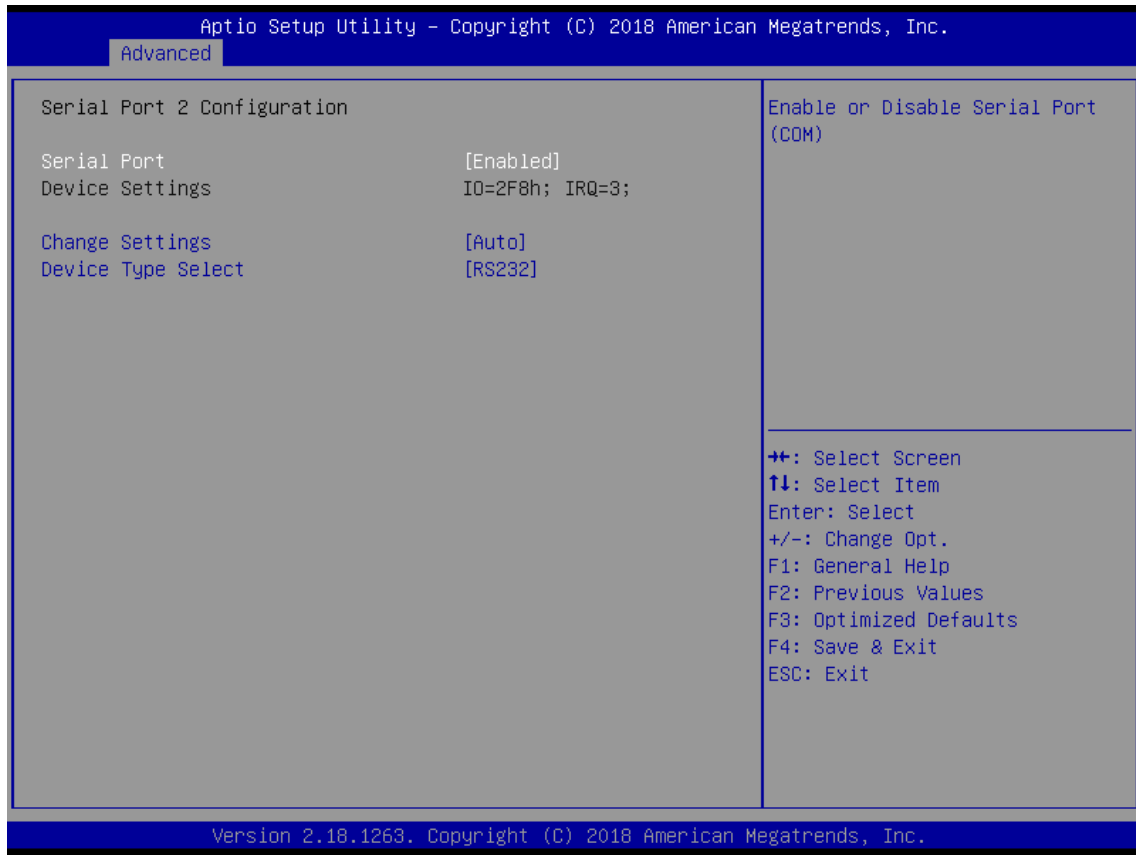

Item	Options	Description
Serial Port	Disabled, Enabled[Default]	Enable or Disable Serial Port (COM).
Change Settings	Auto[Default], IO=2F8h; IRQ=3; , IO=3F8h; IRQ=3,4,5,6,7,9,10,11,12; , IO=2F8h; IRQ=3,4,5,6,7,9,10,11,12; , IO=3E8h; IRQ=3,4,5,6,7,9,10,11,12; , IO=2E8h; IRQ=3,4,5,6,7,9,10,11,12;	This item allows you to change the address & IRQ settings of the specified serial port.
Device Type Select	UART 232[Default], UART 422, UART 485	Set the Serial Port to RS232 & RS422 & RS485
RS-485 Auto Flow Function	Disabled, Enabled[Default]	Enabled/Disabled RS485 Autoflow Function
RS-422/RS-485 Terminal Function	Disabled, Enabled[Default]	RS-422/RS-485 Terminal Function

Serial Port 3 Configuration

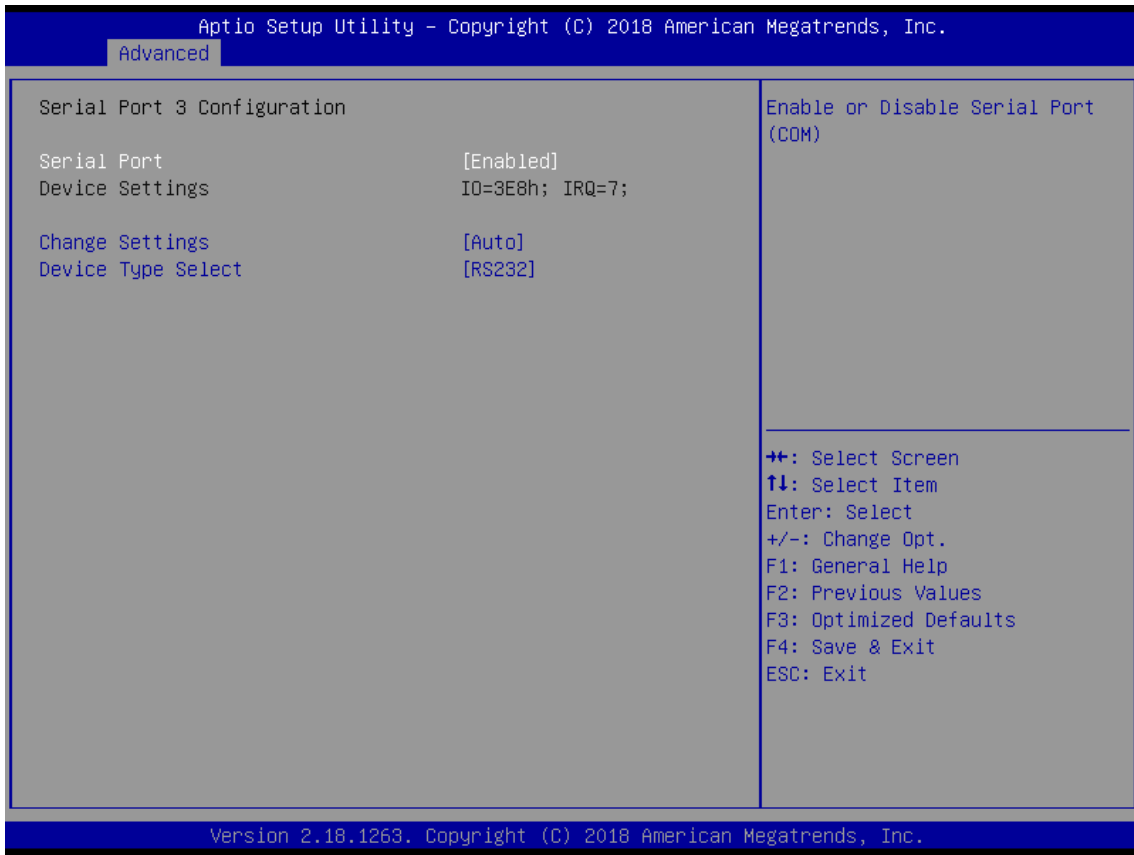

Item	Options	Description
Serial Port	Disabled, Enabled[Default]	Enable or Disable Serial Port (COM).
Change Settings	Auto[Default], IO=3E8h; IRQ=7; , IO=3E8h; IRQ=3,4,5,6,7,9,10,11,12; , IO=2E8h; IRQ=3,4,5,6,7,9,10,11,12; , IO=2F0h; IRQ=3,4,5,6,7,9,10,11,12; , IO=2E0h; IRQ=3,4,5,6,7,9,10,11,12;	This item allows you to change the address & IRQ settings of the specified serial port.
Device Type Select	UART 232[Default], UART 422, UART 485	Set the Serial Port to RS232 & RS422 & RS485
RS-485 Auto Flow Function	Disabled, Enabled[Default]	Enabled/Disabled RS485 Autoflow Function
RS-422/RS-485 Terminal Function	Disabled, Enabled[Default]	RS-422/RS-485 Terminal Function

Serial Port 4 Configuration

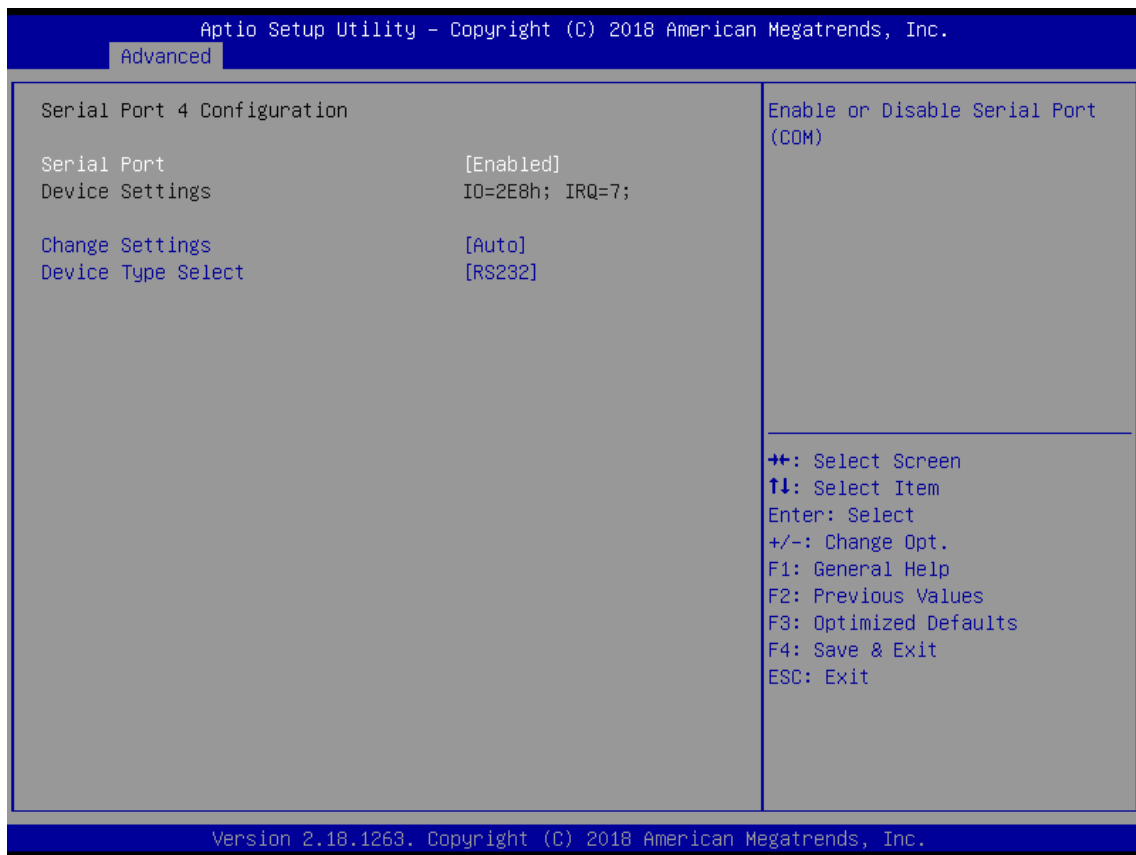

Item	Options	Description
Serial Port	Disabled, Enabled[Default]	Enable or Disable Serial Port (COM).
Change Settings	Auto[Default], IO=2E8h; IRQ=7; , IO=3E8h; IRQ=3,4,5,6,7,9,10,11,12; , IO=2E8h; IRQ=3,4,5,6,7,9,10,11,12;; IO=2F0h; IRQ=3,4,5,6,7,9,10,11,12;; IO=2E0h; IRQ=3,4,5,6,7,9,10,11,12;	This item allows you to change the address & IRQ settings of the specified serial port.
Device Type Select	UART 232[Default], UART 422, UART 485	Set the Serial Port to RS232 & RS422 & RS485
RS-485 Auto Flow Function	Disabled, Enabled[Default]	Enabled/Disabled RS485 Autoflow Function
RS-422/RS-485 Terminal Function	Disabled, Enabled[Default]	RS-422/RS-485 Terminal Function

Serial Port 5 Configuration

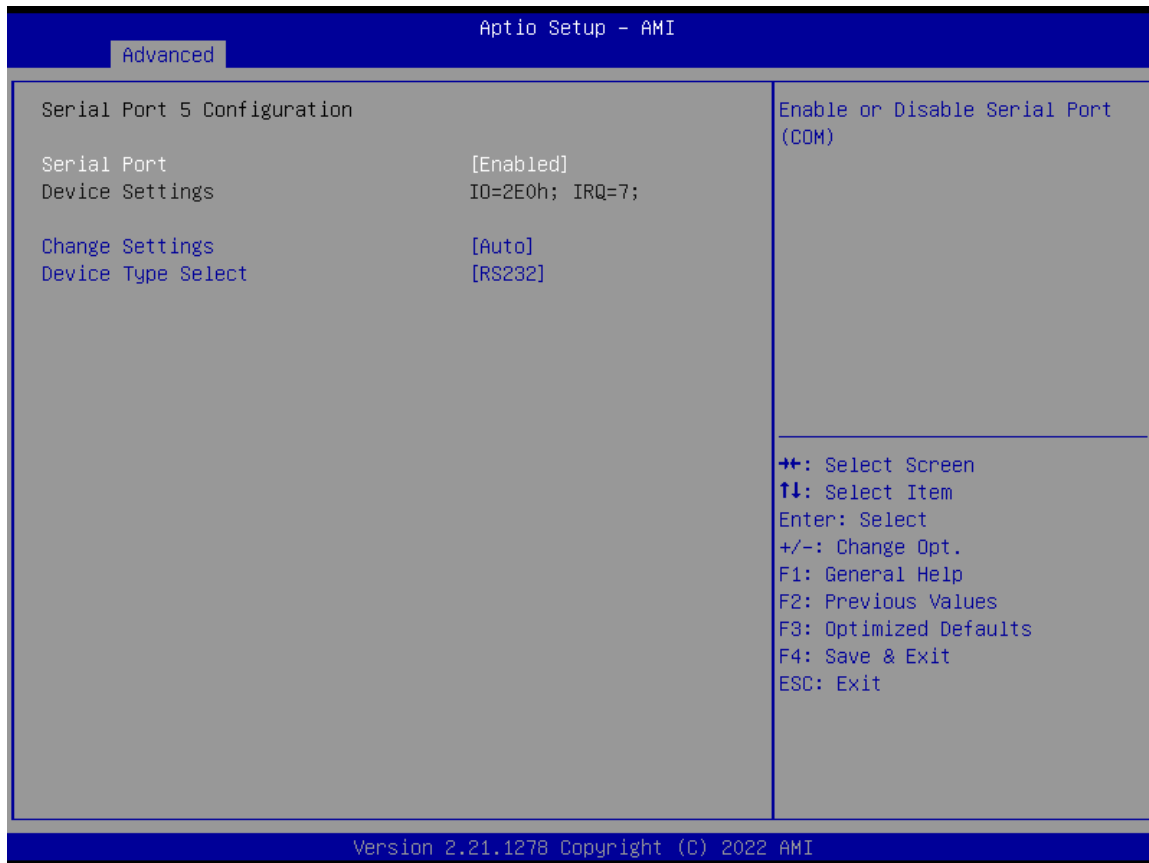

Item	Options	Description
Serial Port	Disabled, Enabled[Default]	Enable or Disable Serial Port (COM).
Change Settings	Auto[Default], IO=2E0h; IRQ=5; , IO=3E8h; IRQ=3,4,5,6,7,9,10,11,12; , IO=2E8h; IRQ=3,4,5,6,7,9,10,11,12; , IO=2F0h; IRQ=3,4,5,6,7,9,10,11,12; , IO=2E0h; IRQ=3,4,5,6,7,9,10,11,12;	This item allows you to change the address & IRQ settings of the specified serial port.
Device Type Select	UART 232[Default], UART 422, UART 485	Set the Serial Port to RS232 & RS422 & RS485
RS-485 Auto Flow Function	Disabled, Enabled[Default]	Enabled/Disabled RS485 Autoflow Function
RS-422/RS-485 Terminal Function	Disabled, Enabled[Default]	RS-422/RS-485 Terminal Function

4.3.9 Hardware Monitor

These items display the current status of all monitored hardware devices/ components such as voltages and temperatures.

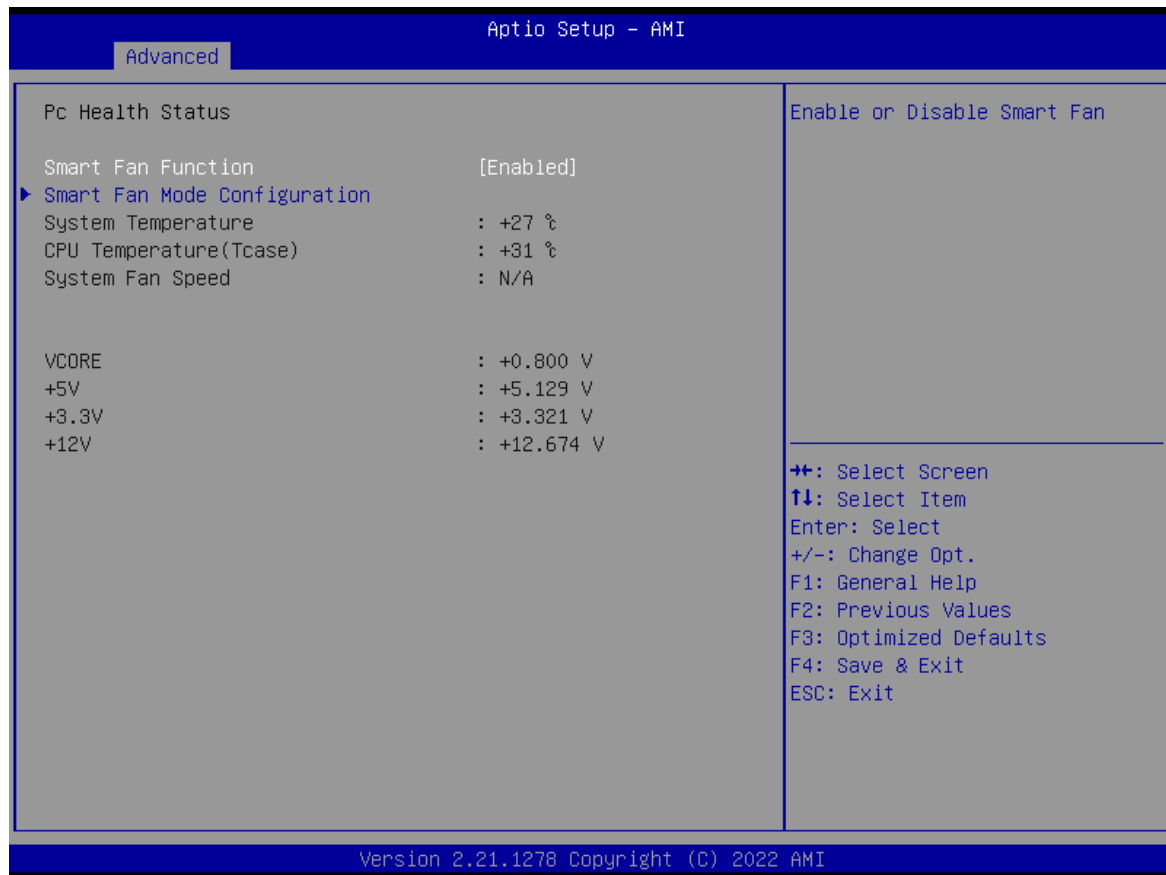

Item	Options	Description
Smart Fan Function	Disabled[Default], Enabled	Enabled or Disable Smart Fan

Smart Fan Mode Configuration

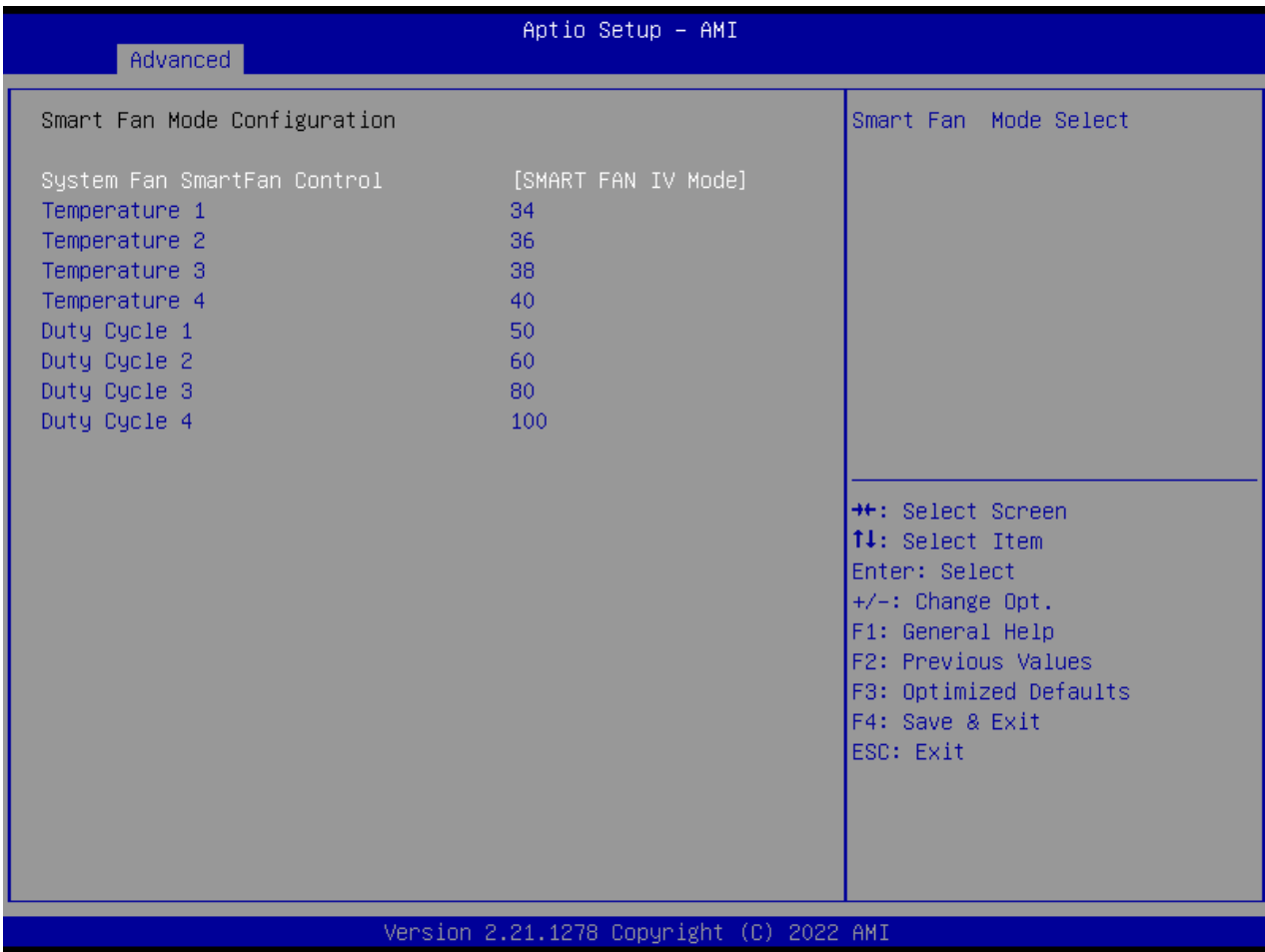

Item	Options	Description
Expansion Fan SmartFan Control	Manual Mode, SMART FAN IV Mode[Default],	Smart Fan Mode Select
Temperature 1~4	1~100	Auto fan speed control. SMART FAN IV
Duty Cycle 1~4	20~100	Auto fan speed control. SMART FAN IV

4.3.10 Serial Port Console Redirection



Item	Options	Description
Console Redirection	Disabled[Default], Enabled	These items allows you to enable or disable COM1 console redirection

4.3.11 USB Configuration

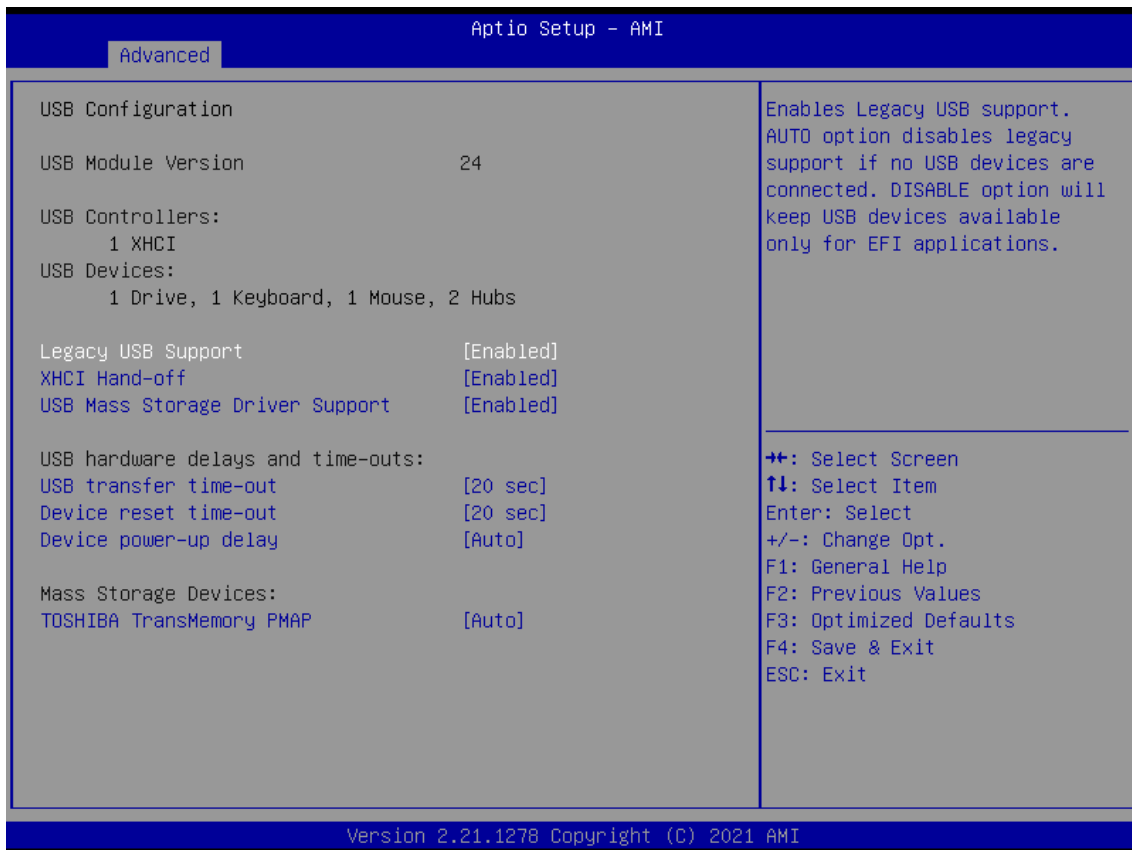

Item	Options	Description
Legacy USB Support	Enabled[Default] Disabled Auto	Enables Legacy USB support. AUTO option disables legacy support if no USB devices are connected. DISABLE option will keep USB devices available only for EFI applications.
XHCI Hand-off	Enabled[Default] Disabled	This is a workaround for OSeW without XHCI hand-off support. The XHCI ownership change should be claimed by XHCI driver.
USB Mass Storage Driver Support	Enabled[Default] Disabled	Enable/Disable USB Mass Storage Driver Support.
USB transfer time-out	1 sec , 5 sec , 10 sec , 20 sec[Default]	The time-out value for Control, Bulk, and Interrupt transfers.
Device reset time-out	10 sec , 20 sec[Default] , 30 sec, 40 sec	USB mass storage device Start Unit command time-out.
Device power-up delay	Auto[Default] Manual	Maximum time the device will take before it properly reports itself to the Host Controller. 'Auto' uses default value: for a Root port it is 100ms, for a Hub port the delay is taken form Hub descriptor.

4.3.12 Network Stack Configuration

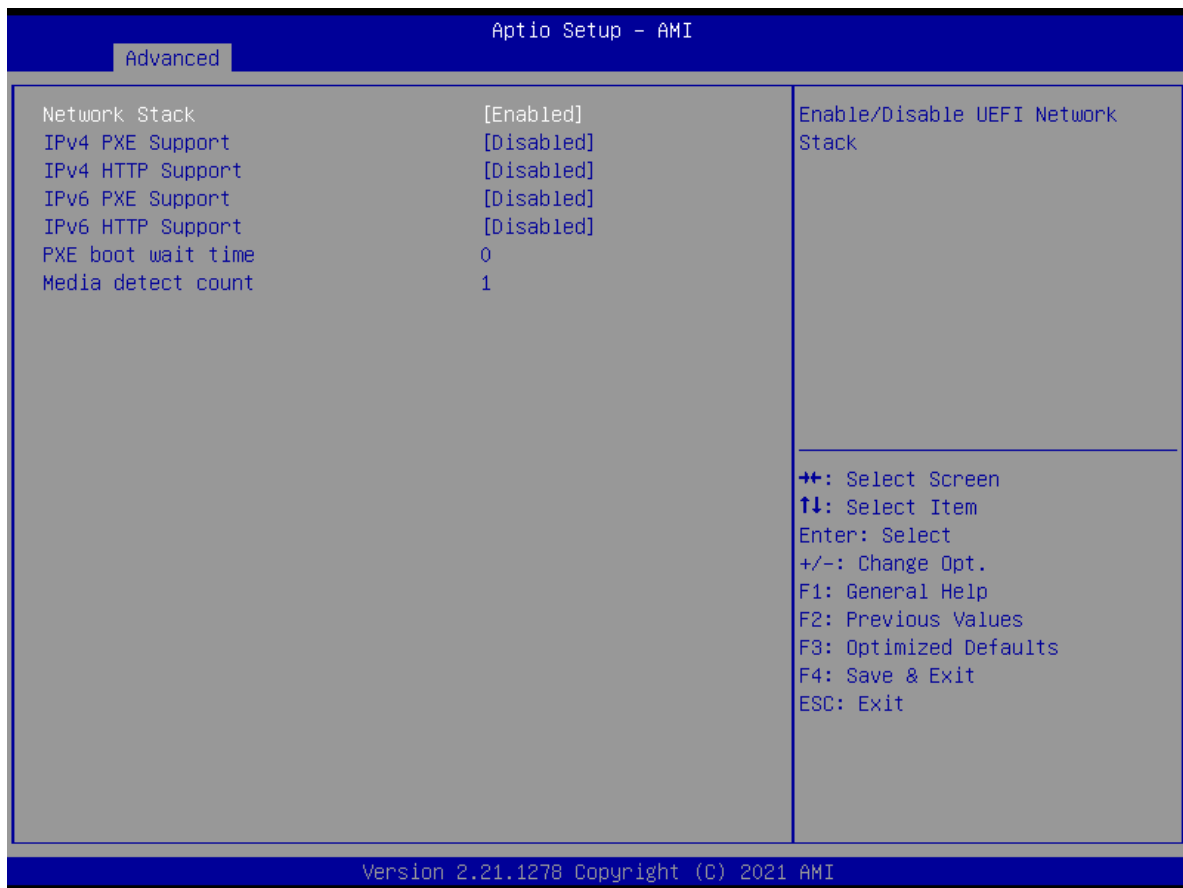

Item	Options	Description
Network Stack	Disabled[Default] , Enabled	Enable/Disable UEFI Network Stack.
IPv4 PXE Support	Disabled[Default] , Enabled	Enable/Disable IPv4 PXE boot support. If disabled, IPv4 PXE boot support will not be available.
IPv4 HTTP Support	Disabled[Default] , Enabled	Enable/Disable IPv4 HTTP boot support. If disabled, IPv4 HTTP boot support will not be available.
IPv6 PXE Support	Disabled[Default] , Enabled	Enable/Disable IPv4 PXE boot support. If disabled, IPv6 PXE boot support will not be available.
IPv6 HTTP Support	Disabled[Default] , Enabled	Enable/Disable IPv6 HTTP boot support. If disabled, IPv6 HTTP boot support will not be available.
PXE boot wait time	0[Default]	Wait time in seconds to press ESC key to abort the PXE boot. Use either +/- or numeric keys to set the value.
Media detect count	1[Default]	Number of times the presence of media will be checked. Use either +/- or numeric keys to set the value.

4.4 Chipset

This section allows you to configure and improve your system and allows you to set up some system features according to your preference.

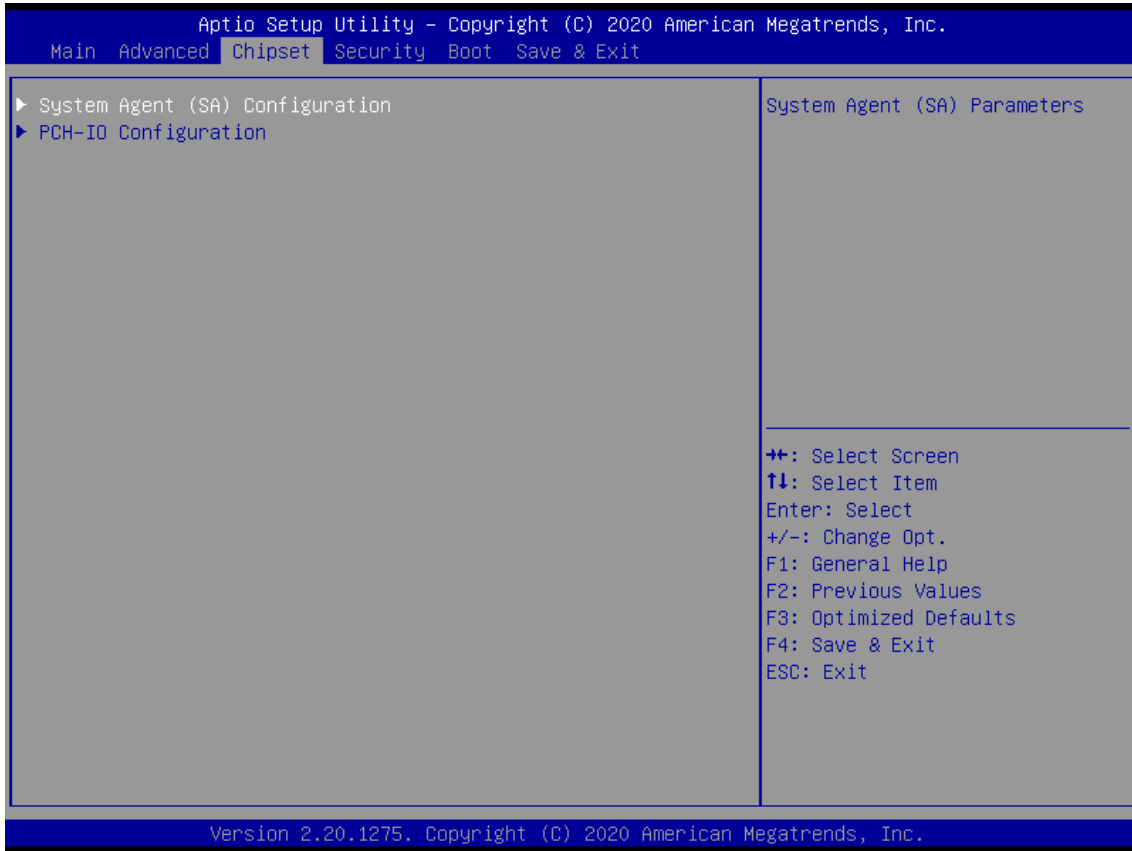

4.4.1 System Agent (SA) Configuration



■ Memory Configuration

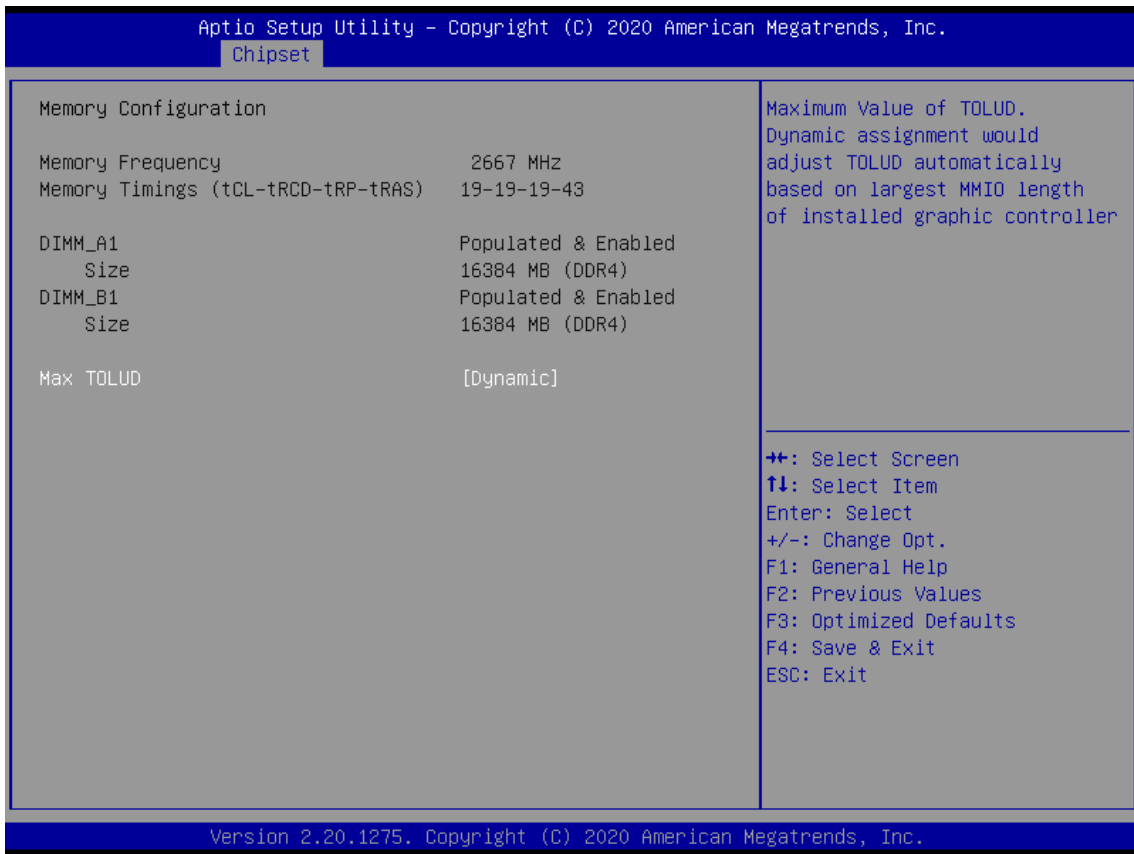

Item	Options	Description
Max TOLUD	Dynamic[Default], 1GB, 1.25GB, 1.5 GB, 1.75 GB, 2 GB, 2.25 GB, 2.5 GB, 2.75 GB	Maximum Value of TOLUD. Dynamic assignment would adjust TOLUD automatically based on largest MMIO length of installed graphic controller

■ Graphic Configuration

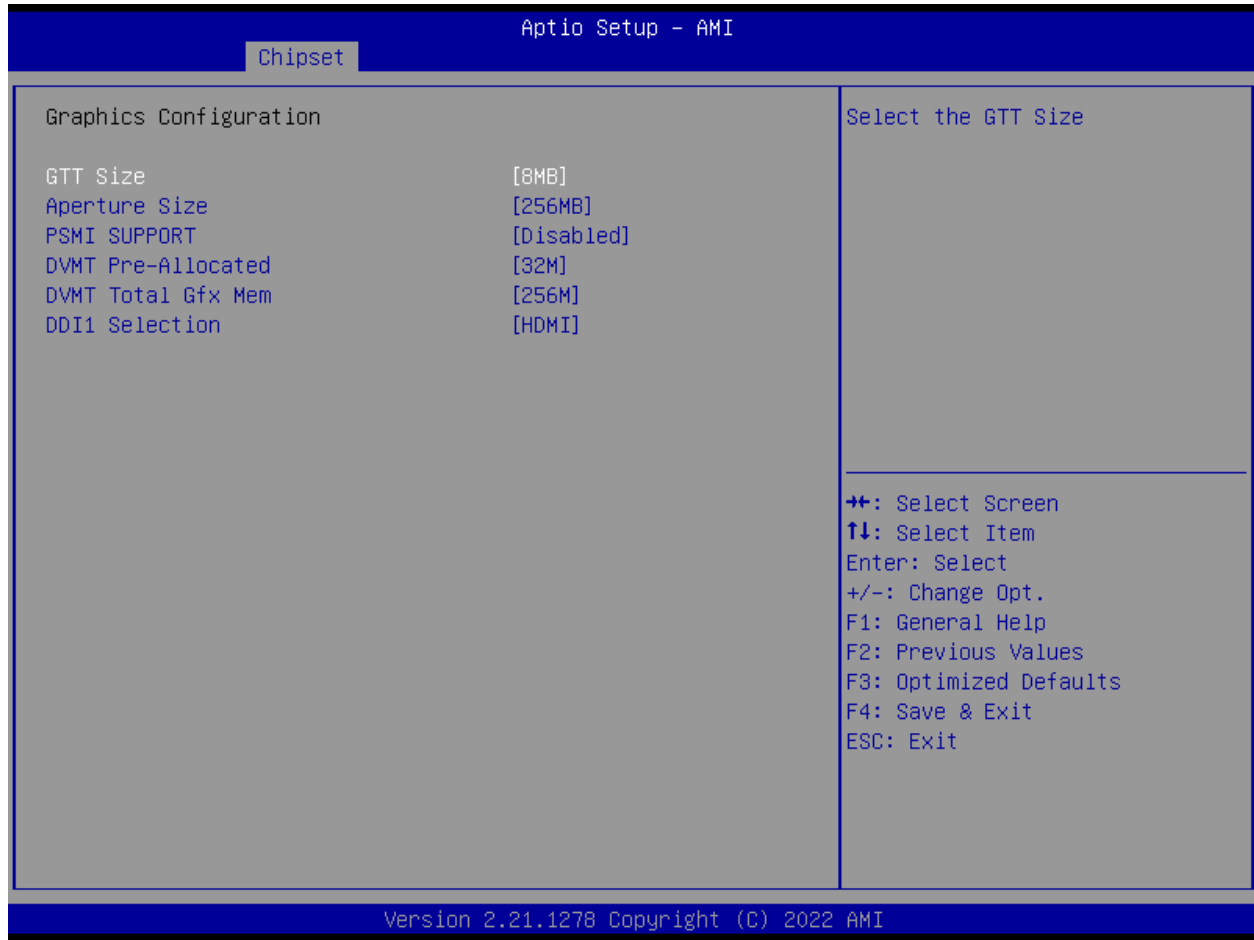

Item	Options	Description
GTT Size	2MB, 4MB, 8MB[Default]	Select the GTT Size .
Aperture Size	128MB, 256MB[Default] , 512MB, 1024MB, 2048MB	Select the Aperture Size. Note : Above 4GB MMIO BIOS assignment is automatically enabled when selecting 2048MB aperture. To use this feature, please disable CSM Support.
PSMI SUPPORT	Disabled [Default] , Enabled	PSMI Enable/Disable.
DVMT Pre-Allocated	32M [Default] , 64M,4M,8M, 12M,16M, 20M, 24M, 28M,32M/F7, 36M, 40M,44M, 48M,52M,56M,60M	Select DVMT 5.0 Pre-Allocated (Fixed) Graphics Memory size used by the Internal Graphics Device.
DVMT Total Gfx Mem	128M, 256M[Default] , MAX	Select DVMT5.0 Total Graphic Memory size used by the Internal Graphics Device.
DDI1 Selection	DP, HDMI[Default]	Selects DDI1 Function: DP or HDMI

4.4.2 PCH-IO Configuration

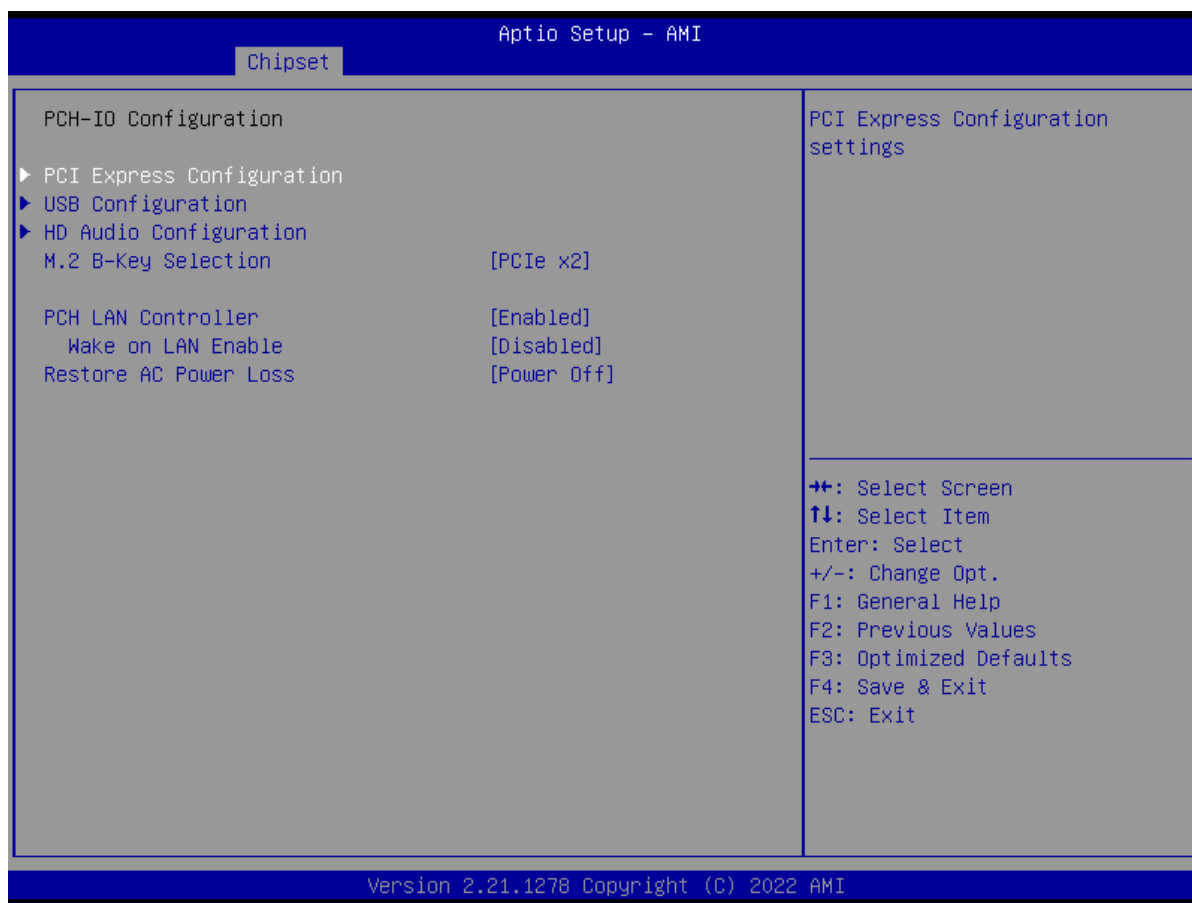

Item	Options	Description
M.2 B-Key Selection	USB + PCIe x1, PCIe x2[Default] ,	Selects M.2 B-KEy function: PCIe x2 or USB + PCIe x1.
PCH LAN Controller	Enabled [Default] , Disabled	Enable/Disable onboard NIC.
Wake on LAN Enable	Enabled, Disabled [Default]	Enable/Disable integrated LAN to wake the system.
Restore AC Power Loss	Power On, Power Off [Default] , Lase State	Specify what state to go to when power is re-applied after a power failure (G3 state).

■ PCI Express Configuration

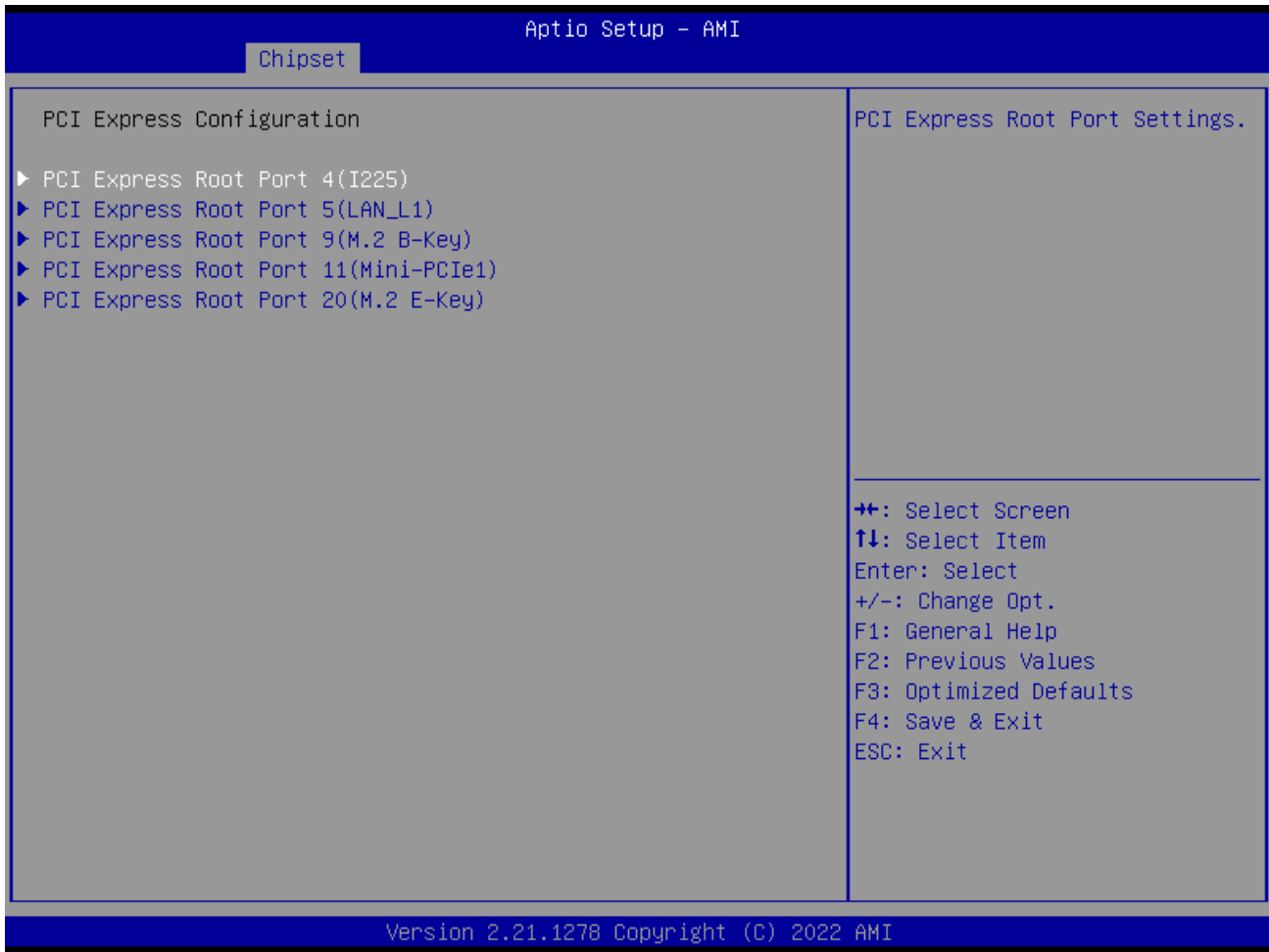

- **PCI Express Root Port 4 /5 /9 /10 /11 /20 /21**

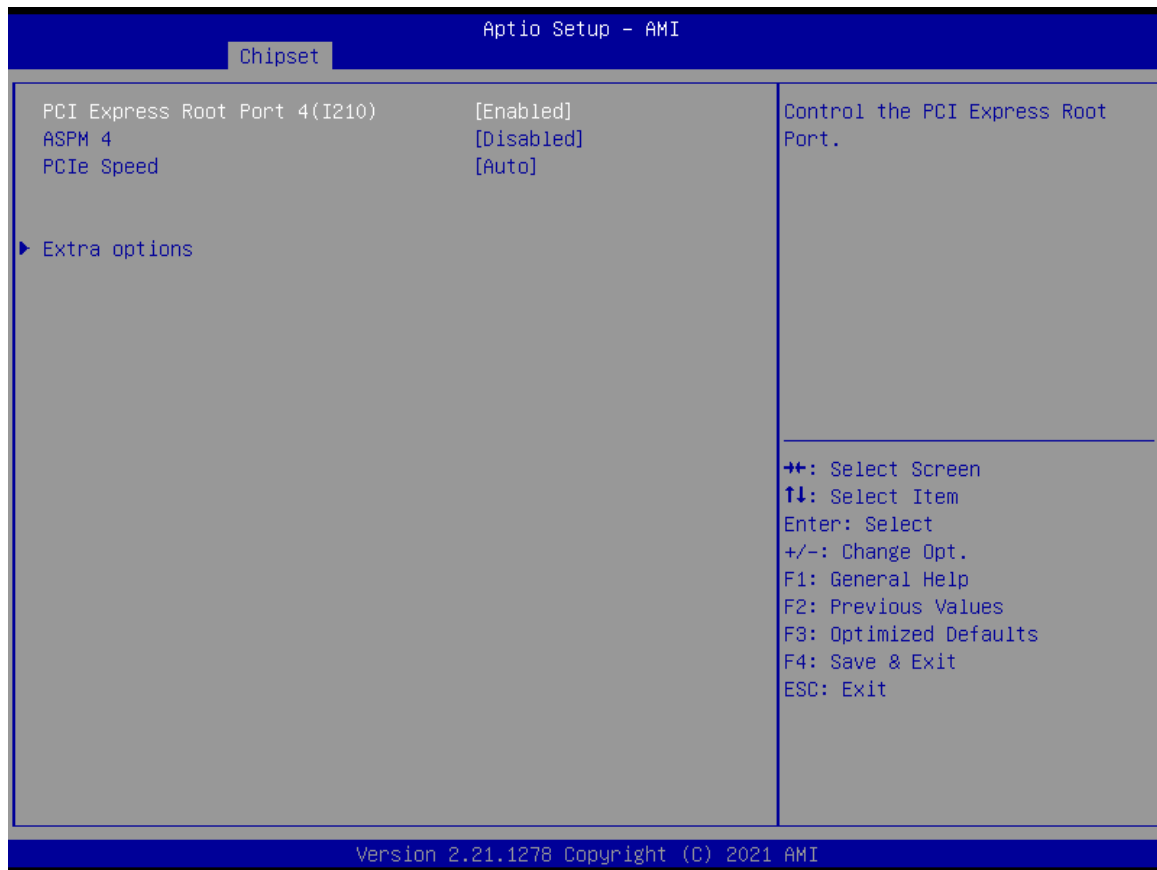

Item	Options	Description
PCI Express Root Port 4 /5 /9 /11 /20	Disabled [Default] , Enabled	Control the PCI Express Root Port.
ASPM	Disabled [Default] , L0s, L1, L0sL1, Auto	Set the ASPM Level: Force L0s - Force all links to L0s State, AUTO - BIOS auto configure, DISABLE - Disables ASPM,
PCIe Speed	Auto [Default] , Gen1, Gen2, Gen3	Configure PCIe speed.
Detect Non-Compliance Device	Disabled [Default] , Enabled	Detect Non-Compliance PCI Express Device. If enable, it will take more time at POST time.

■ USB Configuration



Item	Options	Description
XHCI Compliance mode	Disabled [Default] , Enabled	Option to enable Compliance Mode. Default is to disable Compliance Mode. Change to enabled for Compliance Mode testing.

■ HD Audio Configuration

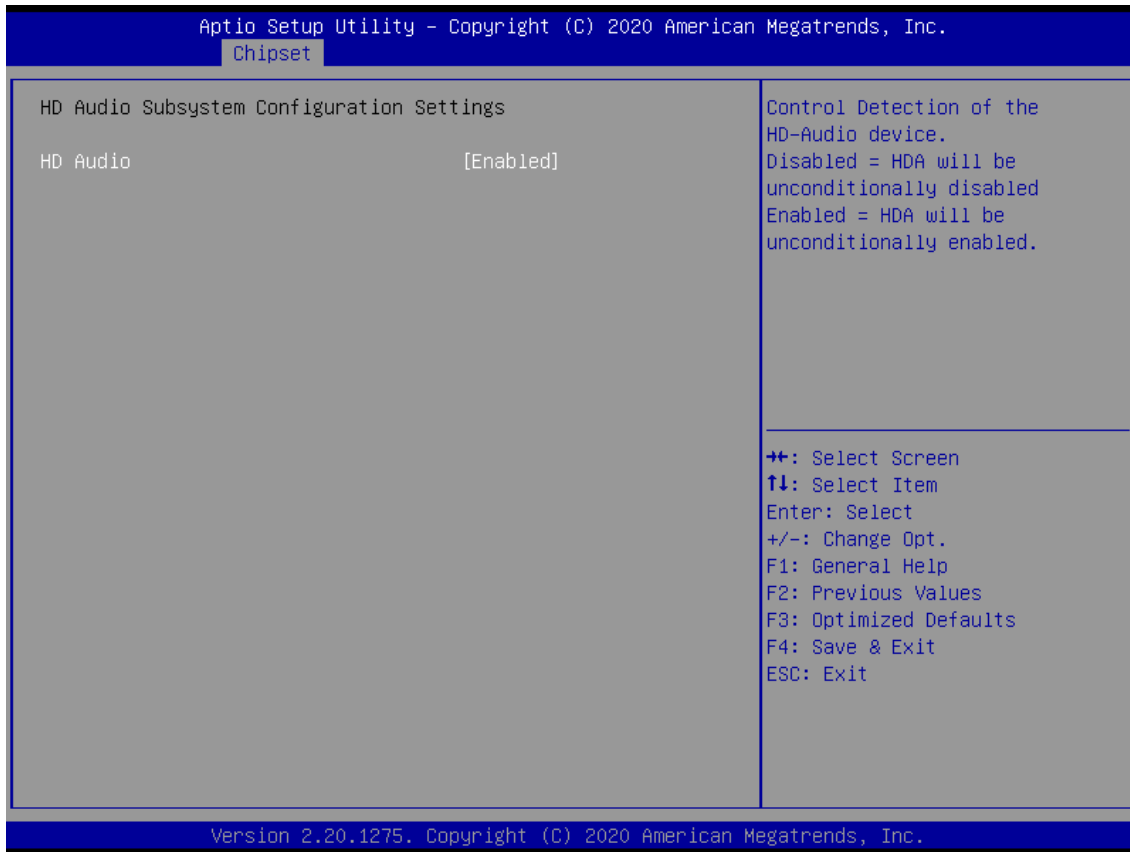

Item	Options	Description
HD Audio	Disabled, Enabled [Default]	Control Detection of the HD-Audio device. Disabled = HDA will be unconditionally disabled Enabled = HDA will be unconditionally enabled.

4.5 Security

Security menu allow users to change administrator password and user password settings.

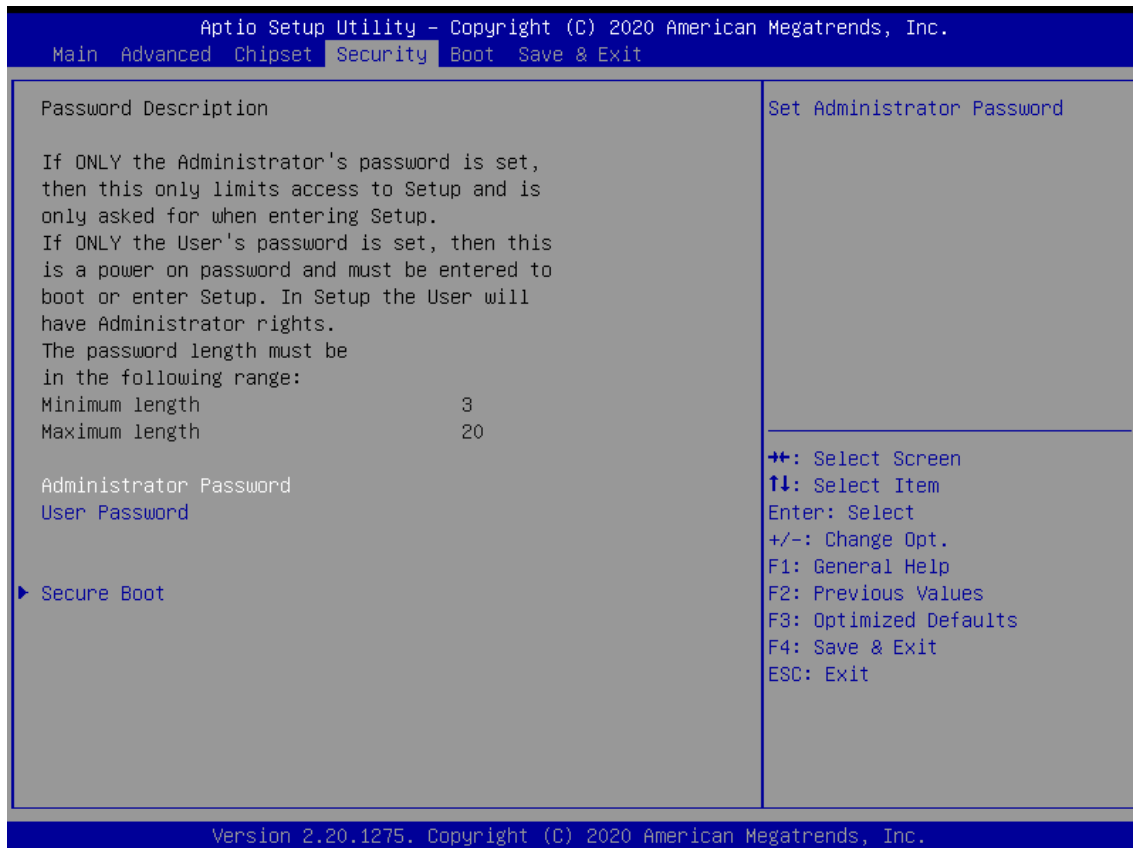

■ Administrator Password

This item allows you to set Administrator Password.

■ User Password

This item allows you to set User Password.

Security Boot

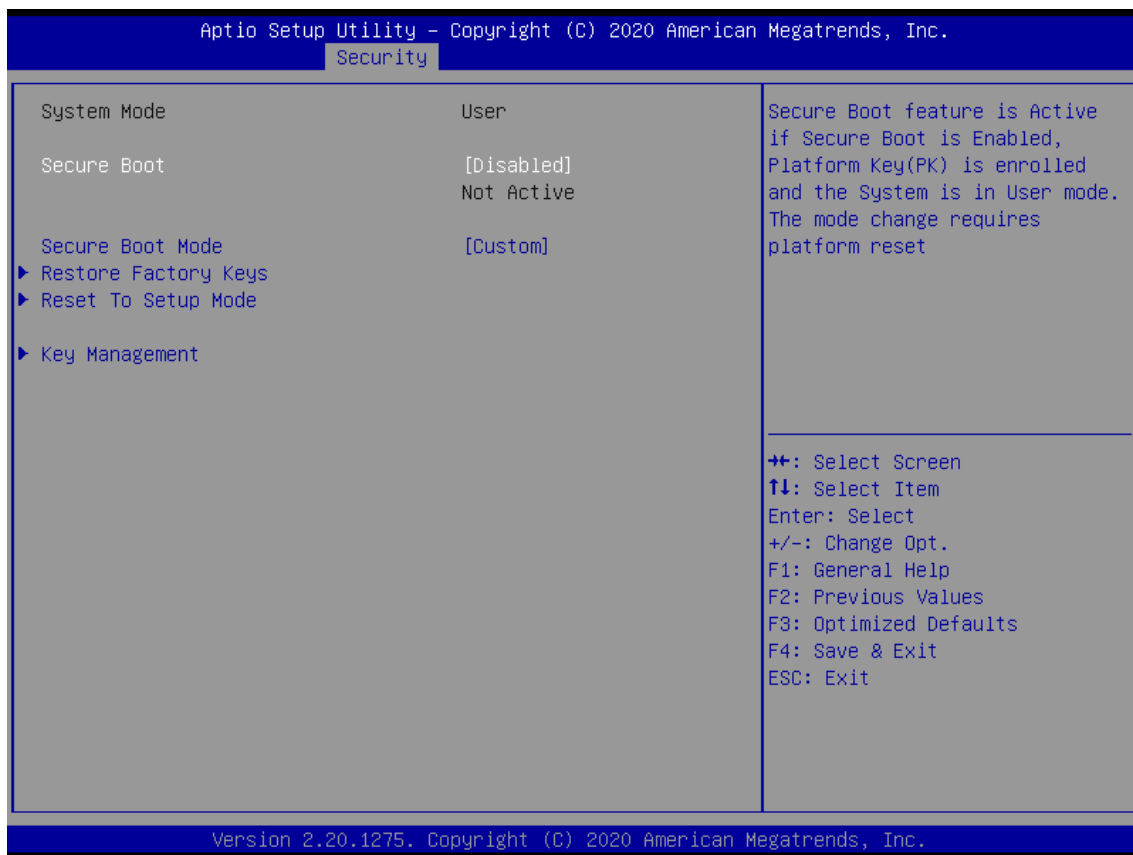

Item	Options	Description
Secure Boot	Disabled [Default] , Enabled	Secure Boot feature is Active if Secure Boot is Enabled, Platform Key(PK) is enrolled and the System is in User mode. The mode change requires platform reset
Secure Boot Mode	Standard, Custom [Default]	Secure Boot mode options: Standard or Custom. In Custom mode, Secure Boot Policy variables can be configured by a physically present user without full authentication

■ Key Management

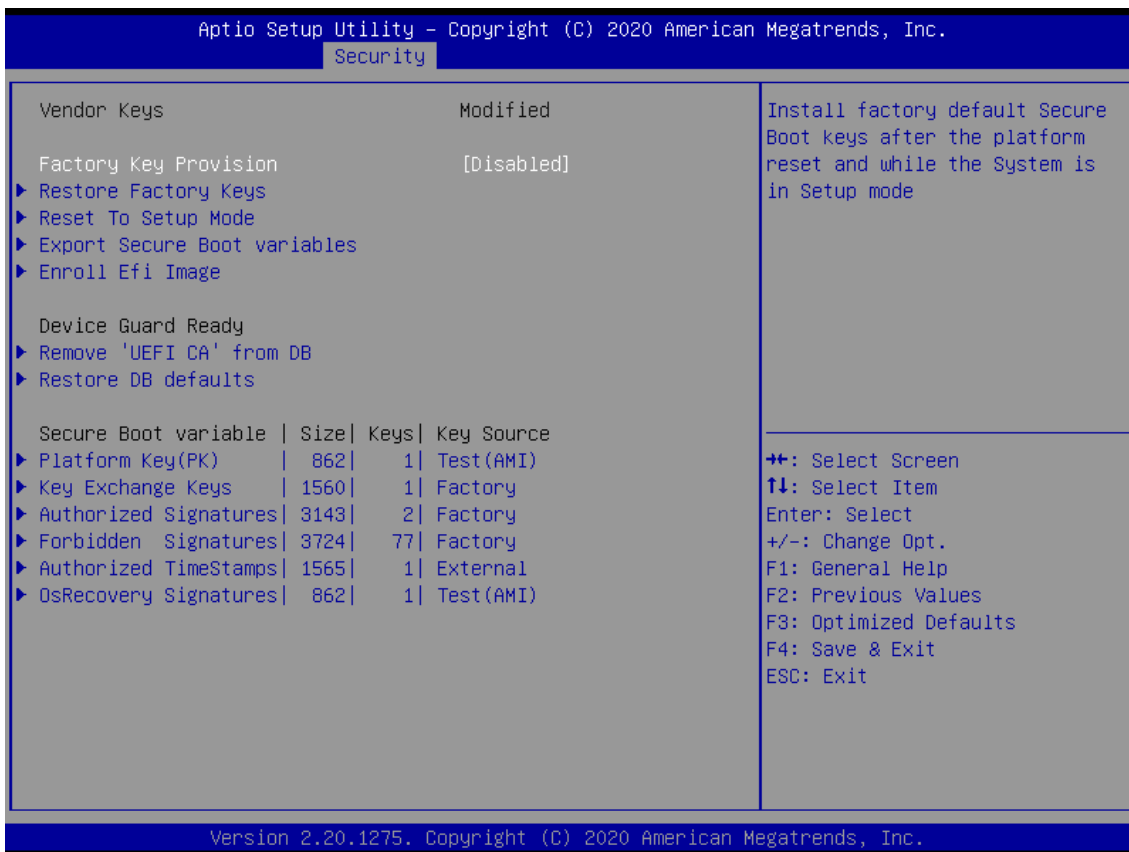

Item	Options	Description
Factory Key Provision	Disabled [Default] , Enabled	Install factory default Secure Boot keys after the platform reset and while the System is in Setup mode

4.6 Boot

This menu allows you to setup the system boot options.



Item	Options	Description
Setup Prompt Timeout	1[Default]	Number of seconds to wait for setup activation key. 65535(0xFFFF) means indefinite waiting.
Bootup NumLock State	On[Default] , Off	Select the Keyboard NumLock state.
Full Screen Logo Show	Disabled[Default] , Enabled	Enables or disables Full Screen Logo Show option.
Boot Option #1		Set the system boot order.

4.7 Save & Exit

This setting allows users to configure the boot settings.

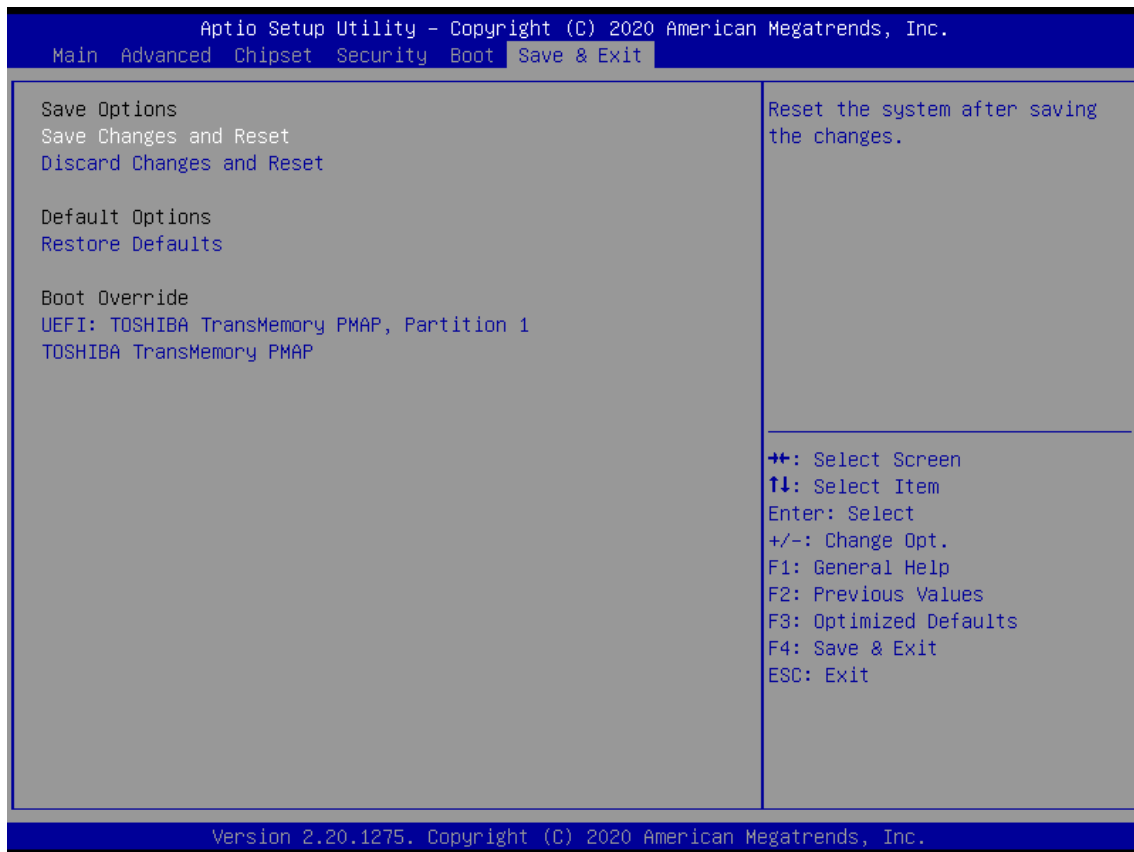

■ Save Changes and Reset

This item allows user to reset the system after saving the changes. This item allows user to reset the system after saving the changes.

■ Discard Changes and Reset

This item allows user to reset the system without saving any changes.

■ Restore Defaults

Use this item to restore /load default values for all the setup options.

Appendix

WDT & GPIO

This appendix provides the sample codes of WDT (Watch Dog Timer) and GPIO (General Purpose Input/ Output).

WDT Sample Code

WDT Setting

Psuedo Code

```
#define AddrPort          0x2e
#define DataPort         0x2f
#define SIO_UnLock_Value 0x87
#define SIO_Lock_Value   0xaa
#define WATCHDOG_LDN    0x08
#define GPIO_Port        0xF1

//Enter_Config
WriteByte (AddrPort, SIO_UnLock_Value);
WriteByte (AddrPort, SIO_UnLock_Value);

//Enter WATCHDOG LDN
WriteByte (AddrPort, 0x07);
WriteByte (DataPort, WATCHDOG_LDN);

//Set count mode
WriteByte (AddrPort, 0xf0);
buf2 = ReadByte (DataPort) & 0xf4; //clear "Select Watchdog Timer I count mode
buf2 |= 0x02; //Enable the Watchdog Timer I output low pulse to the KBRST# pin
// buf2 |= 0x08; //Bit3 = (1:Minute Mode/0:Second Mode)
WriteByte (DataPort, buf2); //Write back

//Set watch dog time value
WriteByte (AddrPort, 0xf1)
WriteByte (DataPort, Time) //Set watch dog time value

// close config mode
WriteByte (AddrPort, 0xaa);
```

GPIO Sample Code

GPIO Setting

PIN#	GPIO#	Default Configuration
18	XCOM-	
17	XCOM+	
16	OUT8	DIO Output8
15	IN8	DIO Input8
14	OUT7	DIO Output7
13	IN7	DIO Input7
12	OUT6	DIO Output6
11	IN6	DIO Input6
10	OUT5	DIO Output5
9	IN5	DIO Input5
8	OUT4	DIO Output4
7	IN4	DIO Input4
6	OUT3	DIO Output3
5	IN3	DIO Input3
4	OUT2	DIO Output2
3	IN2	DIO Input2
2	OUT1	DIO Output1
1	IN1	DIO Input1

The GPIO function is provided by SIO, and it can be accessed through its GPIO index/data port. To access the GPIO register, write index to the index port, and then read/write from/to data port. The configuration is described as below.

Pseudo Code

```
#define AddrPort          0x2e
#define DataPort         0x2f
#define SIO_UnLock_Value 0x87
#define SIO_Lock_Value   0xaa
#define SIO_LDN_GPIO     0x07
#define GPIO_Port        0xF1
```

```
//Enter_Config
```

```
WriteByte (AddrPort, SIO_UnLock_Value);
WriteByte (AddrPort, SIO_UnLock_Value);
```

```
WriteByte (AddrPort, 0x07);
WriteByte (DataPort, SIO_LDN_GPIO);
```

```
//Set OUT1~OUT8Value
```

```
WriteByte (AddrPort, GPIO_Port);
WriteByte (DataPort, 0x00); //set OUT1~OUT8 value, OUT1=Bit0, OUT2=Bit1
```

Bit 7	Bit 6	Bit 5	Bit 4	Bit 3	Bit 2	Bit 1	Bit 0
OUT8	OUT7	OUT6	OUT5	OUT4	OUT3	OUT2	OUT1

```
// Read In1~In8 value
```

```
WriteByte (AddrPort, 0xED);
Data= ReadByte (DataPort); //Read In1~In8 value
```

Bit 7	Bit 6	Bit 5	Bit 4	Bit 3	Bit 2	Bit 1	Bit 0
IN8	IN7	IN6	IN5	IN4	IN3	IN2	IN1

```
// close config mode
```

```
WriteByte (AddrPort, SIO_Lock_Value);
```

